



USER MANUAL FOR SPA

CITYLIFE

/ CONTROL SYSTEMS / KEYPADS / ACCESSORIES /

TABLE OF CONTENTS

Introduction	2
Safety instructions	3
Basic Functions	5
Connection diagram	
Malaga Life	8
Lima Life	9
Palermo Life	10
Lugano Life	11
Manhattan Life	12
Vienna Life	13
Budapest Life	14
Prague Life	15
Firenze Life	16
Initial installation	17
Maintenance	21
Spa chemical treatment	22
Jet Directions	
Malaga Life	25
Lima Life	26
Palermo Life	27
Lugano Life	28
Manhattan Life	29
Vienna Life	30
Budapest Life	31
Prague Life	32
Firenze Life	33
Keypad functions	34
User interface - in.k300	44
Other accessories - The Heat Pump (optional)	47
Smart step manual (optional)	51
Other accessories	
in.grid	66
in.touch 2	67
Wellis Spa Control	72
Wiring diagram - W3000	91
Breaker setting	96
Common hardware issues	98

INTRODUCTION

Congratulations on your new product!

Outside work and family the enjoyment of quality life and calm moments plays an important role in the life of a 21st century man. An evening bath in the spa or tub alone or in company can give you the opportunity to lose track of time and your body and soul can relax. From the world of rationality we get into the world of senses where the cossetting atmosphere of the water provides the perfect conditions for relaxation.

Our design engineers utilised the experiences of the ancient Eastern massage culture and the modern findings of Western hydrotherapy to create spas providing the perfect massage experience.

Develop a peaceful space for relaxation with your product in your home and join the group of the few who seek a positive impact on their environment by establishing internal harmony.

Dive into your spa and enjoy the gently flowing water!

Aeware®, Gecko®, and their respective logos are Registered Trademarks of Gecko Alliance Group. in.yt™, in.ye™, in.yj™, in.touch™, in.stream 2™, DJS™, in.k110™, in.k120™, in.k361™, in.k1001™, in.clear™, and their respective logos are Trademarks of Gecko Alliance Group.

All other product or company names that may be mentioned in this publication are tradenames, trademarks or registered trademarks of their respective owners.

SAFETY INSTRUCTIONS

FOR YOUR SAFETY PLEASE ALWAYS PERFORM THE FOLLOWING PRECAUTIONS. IF YOU DO NOT FOLLOW THE WARNINGS AND INSTRUCTIONS, ITEMS MAY GET DAMAGED, YOU MAY GET INJURED, OR YOU MAY SUFFER FATAL INJURY. IMPROPER INSTALLATION AND OPERATION INVALIDATES THE WARRANTY.

Initial safety warnings

The spa must be powered through a residual current device (RCD) with a rated residual operating current not exceeding 30 mA.

The electrical supply of the spa shall be provided with an all-pole isolating device, allowing complete disconnection from the power supply, with a contact separation in accordance with the applicable electrical installation standards.

Devices and parts containing live parts – except those supplied by protective extra-low voltage not exceeding 12 V – must be inaccessible from the spa.

ABOUT THE ENVIROMENTALLY SAFE WATER DRAINING

The spa must be powered through a residual current device (RCD) with a current release not exceeding 30mA.

The devices and parts which contain active parts – except those which are powered from protective extralow voltage not exceeding 12V – must be inaccessible from the spa.

About the environmentally safe water draining

The water temperature in the spa should never exceed 40°C (104°F). The water temperature is considered safe for a healthy adult at 36 to 38°C. Lower water temperature is recommended for younger children or when the spa is used for more than 10 minutes.

Spa heat can cause hyperthermia!

Symptoms: drowsiness, heaviness

This appliance may be used by children aged 8 years and above, and by persons with reduced physical, sensory or mental capabilities, or lack of experience and knowledge, only if they have been given supervision or instruction concerning the safe use of the appliance and understand the hazards involved.

Children shall not play with the appliance.

Cleaning and user maintenance shall not be carried out by children without supervision.

People with heart disease, low or high blood pressure, circulatory disorders, diabetes, and excessive weight should consult their physician prior to using the spa.

Consumption of alcohol or drugs while using the spa greatly increases the chance of fatal overheating.

A person taking medications should consult a doctor before using the spa as some medicines may cause drowsiness while others may affect the heart rate, blood pressure, and circulation.

Persons who suffer from infectious diseases should not use the spa.

Because high water temperature poses a high risk to the fetus and may cause serious fetal damage we advise that (potentially) pregnant women do not use the spa at a water temperature higher than 38°C. Wet surfaces can be slippery. Note and warn your child about this when entering and leaving the spa. To avoid injury carefully get into and out of the spa.

Do not use the spa if the suction cover is damaged or missing.

Never place any electric device within a 2-meter radius of the spa - it can cause electrical shock. Electric devices fallen into water may cause death, electric shock, or serious personal injuries.

It is prohibited to remove the panels while using the spa.

Water treatment should be carried out with caution. Improperly chemically treated* water may cause skin irritation.

When the spa is not in use, cover the spa with the cover to prevent ultraviolet radiation causing damage to the product.

Do not allow your child to climb on the thermo cover when it is on the water-filled spa.

Do not remove any suction sealing. Do not operate the spa if the suction sealing is broken or missing.



WARNING! *The metallic parts of the pool may become hot when exposed to sunlight and can cause injury!*

Keep your clothes and jewellery away from rotating jets and moving parts.

Test the residual current device before use.

Disconnect the spa from the power supply before servicing its electrical parts. (This operation can only be performed by qualified professionals).

It is strictly prohibited to use the spa in a not completely assembled state (e.g. detached side panel)

Chemical treatment of water can only be performed by persons under the age of 18 under parental supervision.

Maintenance can only be performed by trained professionals.

The user should check the electrical wiring every 3 months. It is required to perform a check by a professional every 3 years.

Mains fuses / circuit breakers may be activated because of power outages.

Installation and wiring of the spa, replacement of power cord, and any repairs must be performed by qualified professionals.

It is required to build in an isolating device to the fixed wiring.

Plug'n'play safety warnings

Beyond the previous warnings, please also pay attention to the undermentioned ones.

ATTENTION! *The electrical receptacle must be located at least 2.5 meters from the spa so that bathers in a sitting position cannot reach it from the water. The plug can only be connected to a receptacle* equipped with 2.5mm 2 diameter cables*

ATTENTION! RISK OF ELECTRIC SHOCK. *The connector with residual current device must be inspected before every use.*

ATTENTION! *Only place the RCD plug in a receptacle equipped with RCD.*

ATTENTION! *Before you insert the plug into the socket ensure that the current of the socket and the fixed wiring is appropriate for the properties of the spa.*

The spa must be equipped with an isolation transformer or powered through a residual current device with a release current not exceeding 30mA.

THIS PRODUCT IS EQUIPPED WITH A GROUND FAULT CIRCUIT BREAKER (GFCI) IN THE CONNECTOR. GFCI MUST BE TESTED BEFORE EACH USE.

If the power cable is damaged, it must immediately be replaced by the manufacturer or a service professional in order to minimize danger.

To minimize the risk of electric shock do not use extension leads to connect the product to the power supply.

Ensure that the receptacle is properly located.

Parts of the equipment cannot be placed above the spa during usage.

Parts under electrical power – except those operating with voltage not exceeding 12V - must be inaccessible for persons in the spa. The grounded device must be connected to a fixed socket with fixed wiring. Electrical parts – except remote controllers – must be positioned so as not to fall into the spa.

SAFETY INSTRUCTIONS

The electrical installation must meet the local standard requirements.

To avoid electric shock do not use the spa in rain.

Water attracts children. Always place and lock the cover on the spa after each usage.

Do not bury cables into the ground! Place the cables so that lawnmowers, trimmers, and similar devices will not reach them.

Do not force push the control panel up nor down and do not place heavy objects on it after installation.

Keep pets away from the spa to avoid damage.

Do not use the device if there is the slightest chance of water in the spa being frozen.

Only use accessories approved by us. The use of accessories not approved by us may void the warranty.

Choking hazard. Particular attention need to be paid to children during usage. To avoid accidents only allow children to use this spa under adult supervision.

Never operate electrical devices in the spa or with wet body. Do not place electrical devices (lamp, radio, television) within a 1.5m radius of the spa.

Do not expose the spa to direct sunlight.

Only connect the spa to an earthed socket.

Risk of electric shock. Install the unit at least 1.5m (5 feet) from any metal surfaces. You can install the unit 1.5m from metal surfaces only if every metal surface is permanently connected to a solid copper conductor

with a diameter of at least 6mm, which is connected to the cable connector of a junction box reserved for that purpose.

To avoid injury never pour water warmer than 40°C directly into the spa.

Effects of overheating: you cannot assess emergency situations, do not feel the temperature, do not feel the need to get out of the spa, cannot get out of the spa; risk of fetal damage in pregnant women, loss of consciousness, suffocation.

Do not use the spa alone.

Do not use the spa immediately after strenuous sport.

To prevent damage to the pump the spa can only be operated if it has been filled with water.

If you feel uncomfortably or sleepy, leave the spa immediately.

Never add water to the chemicals. Always be cautious when adding chemicals to the spa water to avoid inhaling vapors and possible effects of inhaling undiluted chemicals and splatters.

Only place the spa on a surface that can support its weight.

INSPECT THE UNIT BEFORE USE. CONTACT THE SERVICE PROVIDER STATED IN THIS MANUAL IF ANY OF THE PARTS WERE DAMAGED OR MISSING UPON PURCHASE. ENSURE THAT THE PARTS OF THE UNIT ARE THOSE WHICH YOU INTENDED TO BUY.

IN.CLEAR SAFETY WARNINGS

Beyond the previous warnings, please also pay attention to the undermentioned ones

Read this manual carefully, always follow its instructions, and retain it. This manual contains important information about the installation, operation, and safety recommendations of the in.clear unit. Safe installation and usage is your responsibility.

The in.clear unit must be connected to a network protected by a ground fault circuit interrupter (GFCI) of the maximal nominal fault current value of 30mA.

Ensure that the entire power supply is turned off before the in.clear unit is installed.

If the power cord is damaged, it must be replaced by the manufacturer, an authorized service provider, or qualified professionals to avoid emergencies.

Always use a proper electric cable for supply of current to the in.clear unit.

When installing the in.clear Automatic Bromine Generator local and international electrical regulations must be complied with.

Clean or replace the filter cartridge at regular intervals, otherwise part of the bromine produced by the in.clear unit will be consumed by oxidation of contamination accumulated in the filter.

DO NOT pour any other chemicals into the spa than the recommended sodium bromide. DO NOT use any ozone or UV disinfectant.

Operating the in.clear unit on lower sodium bromide level shortens the life of the cells. Keeping sodium bromide and bromine levels above the recommended level may lead to corrosion of the spa components and cause damage to the spa accessories.

Do not open the in.clear unit; it does not contain serviceable parts

Product disposal: the in.clear unit must be disposed of in accordance with local disposal regulations in force.

This device is not intended for use by persons (nor children) with limited physical, sensory, or mental capabilities except if these persons have received appropriate instruction on use of the device from the person responsible for their safety.

The in.clear unit cannot be applied to in-ground sunken spas as it may affect materials used in the construction.

The shut-off device must have fixed wiring in accordance with the cabling regulations.

Showering is compulsory before each spa use.

The user is responsible for regular monitoring of the spa water to ensure that enough bromine is available to reach the appropriate cleaning level. Intensive spa use may require higher bromine intake to always maintain appropriate bromine level.

Always check the expiry date of the test kit, because after this date the test results may be inaccurate.

For proper disinfection spas must periodically be completely drained. The advised time period between full drains given in days is calculated by dividing the capacity of the spa in litres by the tenfold of the average daily users.

The in.clear unit is applicable for indoor spas, but NOT for swimming pools.

Distinguishing Between P&P and Non P&P Installation:

It's important to differentiate between Plug & Play (P&P) and Non Plug & Play (Non P&P) installation methods as they impact the setup of the spa, particularly regarding the securing of the spa and the placement of wires.

Non P&P Installation:

In cases where the spa is not set up as a Plug & Play system, it is necessary to secure the spa to prevent the power cord from mechanical damage. This is particularly crucial if the pool is not sunk into any level.

The movement of the pool constitutes a reinstall in every case, please ensure that the pool cannot move.

P&P Installation:

Place the spa in range of a socket, plug in the power cord. Check if the spa is powered. When placing the spa relative to the socket, please be mindful about tripping hazard.

BASIC FUNCTIONS

Keypads: The keypads make it possible to control and set up the spa. Available basic functions: pump(s), light and temperature control. (For more information see the details later)

Valves

Diverter: Some spa are equipped with water diverter(s) that allows you to direct the waterflow to various sections of the spa. The valve has three basic positions By turning the lever all the way to the left position will divert the water section A of the spa. By turning the lever all the way to the right will shut off section A and divert the water to section B and by moving the lever to the middle between A & B will divert the water to both A & B sections

Waterfall diverter: Some spas are equipped with a waterfall diverter which will turn the waterfalls/fountains either on or off

Air regulators: You can use it by turning the lever counter-clockwise, will open the Air Regulator to allow air to mix with the water to create more pressure from the jets. Turning the lever to the left will close the valve not allowing air to mix with the water for the jets. These air regulators should remain closed when the spa is not in use to save energy.

Speakers (Optional): If your spa is equipped with an audio system, you can connect via Bluetooth and help your relaxing with your favourite music. (MyMusic pin:2288)

Filter house: Part of the recirculating system, it holds the paper filter.

Fountain: Some spas are equipped with fountains or waterfalls. If you open the waterfall diverter, the water will flow through the fountains or waterfalls.

Jets: There are 3 sizes of jets; the 5" and 3" jets have two types: directional and rotational. The 2" jets are only directional. To open the jet face is turned clockwise. To lessen the pressure or to close, the jet face is turned counter-clockwise

Aroma therapy: You can stimulate your senses with different aromas. You can get aroma into the water if you push the button on the top of the tank. you can block the button if you turn it.

Suction: The pumps suck the water through this element. Never block it, and keep your body and hair away from these units.

Head rests



Keypads



Diverter, Air regulator, On/off valve



Speakers



Filter house



Fountain



Jet (5"-direct, rotational; 3"-direct, rotational; 2"-direct)



Suction



Instructions for Reading the Code on the Data Card:

Locate the data card on your spa, usually situated beneath the side panel, typically on the same side as the control panel. Utilize the table provided on the following page to decipher the internal code to determine the spa specification.

Example of data card:

MANUFACTURER / HERSTELLER / VÝROBCA / FABRICANT / GYÁRTÓ	Wellis®
INTERNAL ORD. NR. / BELSŐ MEGR. SZ.	E414141
MODEL	Malaga Life
TYPE	WM3O*GCECBD2****HIMNE**WNNN
SERIAL NUMBER / SERIAN NUMMER / VÝROBNÉ ČÍSLO / UMERO DE SERUE/ GYÁRTÁSI SZÁM	WM00541-41
Date of production / Herstellungsdatum / Gyártás dátuma	240314
max. POWER / LEISTUNG / TELJESÍTMÉNY	8 kW
CONTROL PANEL / BEDIENUNGSTASTE / KEZELŐ	IN.K500
Wellis Magyarország Zrt. Hungary-2371, Dabas. Mánteleki út hrsz.: 0417	 400V 3N~

WM1ARDCACBE1D1**W1NO*L*WEWN

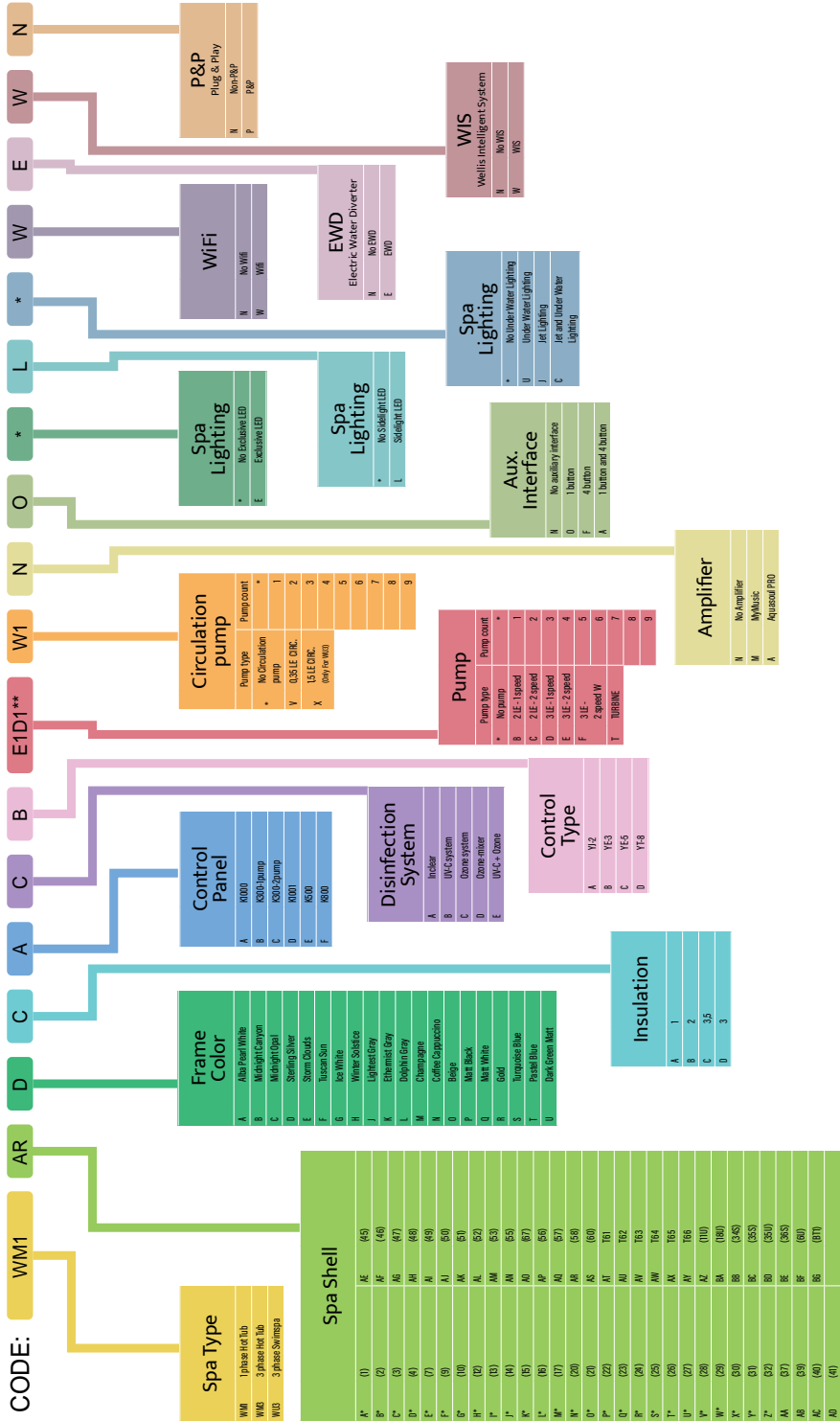

CONNECTION DIAGRAM

MALAGA LIFE

No.	Mt. No.	IFB Name	Fit
1	AKU0242	Heat housing with seal	18
2	AKU0249	Heat housing with seal	18
3	AKU0246	Heat housing with seal	18
4	AKU1891	Water Diverter - house led lighted V2	F
5	AKU1892	Air Regulator - house led lighted V2	3
6	AKU0265	On-Off tap house V3 transparent V2	2
7	AKU0265	Fountain laminar V3	3
8	AJ00291	Air ozone with sealing V2	1
9	AKU1830	Filter house for flooding 50 std fillers	1
10	ABE0205	Beach/leig haz. 2 from (magical) kommissien V2	3
11	AJ00382	Air water circulation self-filling medium gray for life	1
12	AC-M0060	Spa Pump 3 HP - One Speed	2
13	AC-M0846	Circulation pump. WTCSDM 250 W.O. 3 Hp	1
14	ABE0421	Ozon mixer - Housing	E
15	ABE0420	Mixer housing	1
16	AJ00281	Sealing for self adjusting suction heater roll Life	1
17	AC-M0755	Control box in YE-3	1
18	AC-M0959	Control Panel - IN J500 GECKO	3
19	AC-M0854	Receiver 3' (2 wavy)	2
20	AC-M0935	Control for speaker 3' (2 wavy)	2
21	AC-M0014	Jet S2 - transparent 1 Hole V3 Wells	2
22	AJ00214	Jet S2 - transparent 1 Hole V3 Wells	14
23	AJ00017	Jet S2 - transparent 1 Hole Backlash transparent V3 Wells	8
24	AJ00018	Jet S2 - transparent 1 Hole transparent V3 Wells	8
25	AJ00019	Jet S2 - transparent 1 Hole rotational transparent V3 Wells	4
26	AKU1833	Filter House - Skimmer Cover round	1
27	AKU1894	Water Diverter - Grip White V2	3
28	AKU1895	Air regulator grip White V2	1
29	AKU1896	On-off tap grip White V2	2
30	AK00061	Flow 300x26x654 white ribbed	3
31	AKU1842	Skimmer house with Wells top	1
32	AC-M1092	ILL ozone	1
33	AC-M0961	LED control flow	1
34	AC-M0901	WiFi receiver in touch 2 Gecko EIAUK	1
35	AC-M0943	Amplifier Bluetooth for music system Sherman 2.0	1

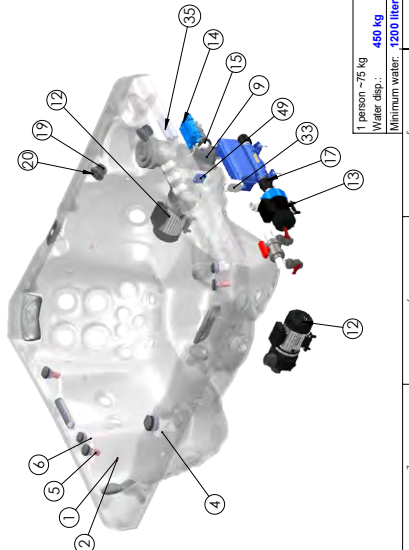
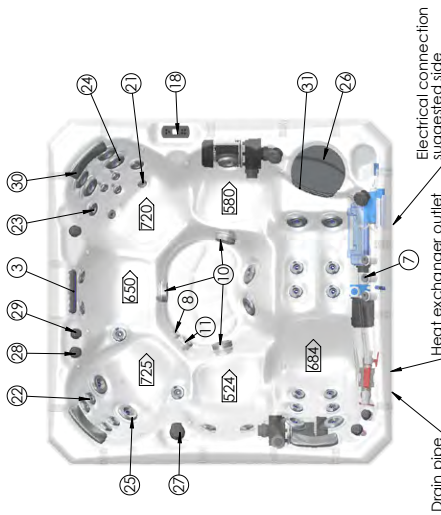

You must install a 30 mA residual-current device (RCD).

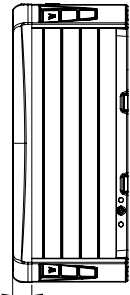

Product family: **WellaCityLife**

Sheet name: **Malaga Life spa**

File name: **EI_WM00541_EMC_Malaga_Life_malaga**

Dimension SPA: **2180x2160x500 mm** | Min E. ins: **230 V - 25A - 50Hz** | Opt. E. needs: **400V - 3x16A - 50Hz**

Weight of the SPA: **338 kg** | Packing **2200x350 RCD** - **AE00382** | **Control box Gecko IN YE3 (BX10) + IN V300**

Part name: **149 mm** | Approved by: **rest tams** | Part Number: **WM00541**

Created: **2024. 04. 17.** | Drawer: **rest.tams** - **2024. 04. 17. 11:11:40** | AS T M 120 | page 1/2

1 person - 75 kg
Water disp.: **489 kg**
Minimum water: **1200 liter**

CONNECTION DIAGRAM

LIMA LIFE

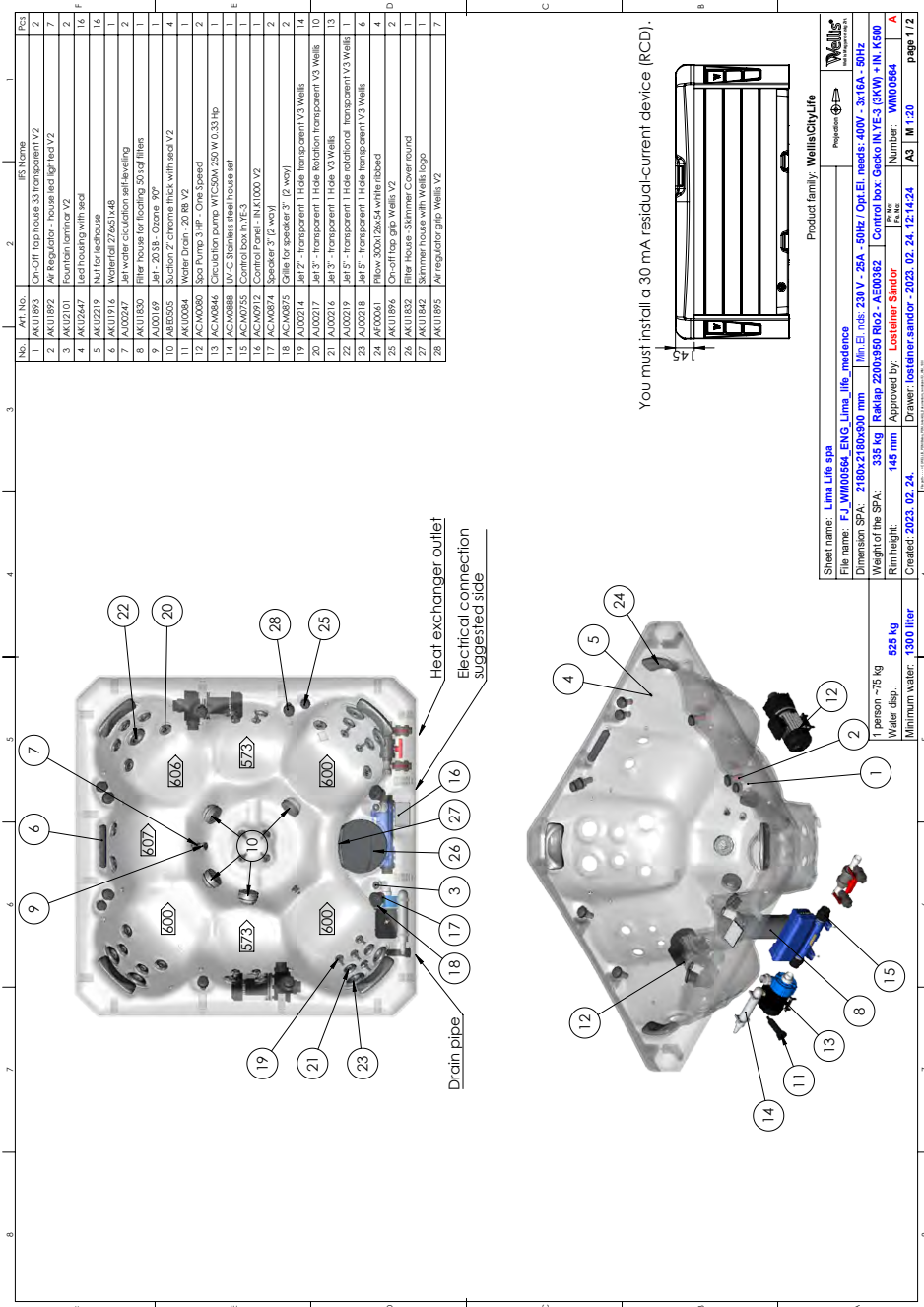

CONNECTION DIAGRAM

PALERMO LIFE

Tétel	Cikkszám	ISMegnevezés EN	Db
1	AKU19447	led housing with seal	16
2	AKU19219	Nut for technose	16
3	AKU19116	Waterfall 2/6x5/4x8	1
4	AKU18953	On-Off top house 33 transparent V2	2
5	AKU18922	Air Regulator - house led lighted V2	2
6	AKU1891	Water Diverter 60 - LED lighted V2	2
7	AKU19245	Fountain tapmat V3	4
8	AJU0281	Sealing for self adjusting suction head mul life	1
9	AKU1830	Filter house for floating 50 sqd liters	1
10	AJU0091	Jet ozone with sealing V2	1
11	ABE5055	Bevödlög ház 2 körm (magas) tömítéses V2	4
12	AJU0092	Circulation jet Medium gray 48 mm life	1
13	ABE5036	Ball valve 32	2
14	AKU1894	Water Drain - 20 RB V2	1
15	ACM1000	Spot Pump 3 HP - One Speed	1
16	ACM1000	Spot Pump 3 HP - One Speed	1
17	ACM10846	Circulation pump W/CSDW 250 W 0.33 Hp	1
18	ABE1621	Ozon mixer - Housing	1
19	ABE1620	Mixer housing	1
20	ACH0755	Control box in VE-3	1
21	ACM0959	Control Panel - INK500 GECKO	1
22	ACM0874	Speaker 3" (2 way)	2
23	ACM0875	Grille for speaker 3" (2 way)	2
24	AKU1894	Water Diverter - Grip Wells V2	1
25	AKU1895	Air regulator grip Wells V2	2
26	AKU1896	On-off tap grip Wells V2	2
27	AJU0219	Jet 5" - transparent 1 Hole rotational transparent V3 Wells 6	6
28	AJU0218	Jet 5" - transparent 1 Hole transparent V3 Wells 6	6
29	AJU0216	Jet 3" - transparent 1 Hole transparent V3 Wells 6	6
30	AJU0217	Jet 3" - transparent 1 Hole rotational transparent V3 Wells 6	6
31	AJU1842	Stirrer house with Vreis Egg	1
32	AJU1832	Flow 300x 265x4 white ribbed	3
33	AJU1832	Flow 300x 265x4 white ribbed	3
34	AKU1831	Spot Filter 337 x 124 white 80 ad (no thread)	1
35	ACH0943	ME receiver in touch 2 Ceramic EU/UK	1
36	ACH0903	ME receiver in touch 2 Ceramic EU/UK	1
37	ACH0945	Amplifier filterbooth for Shenzhen 2.0 Sound System	1

You must install a 30 mA residual-current device (RCD).

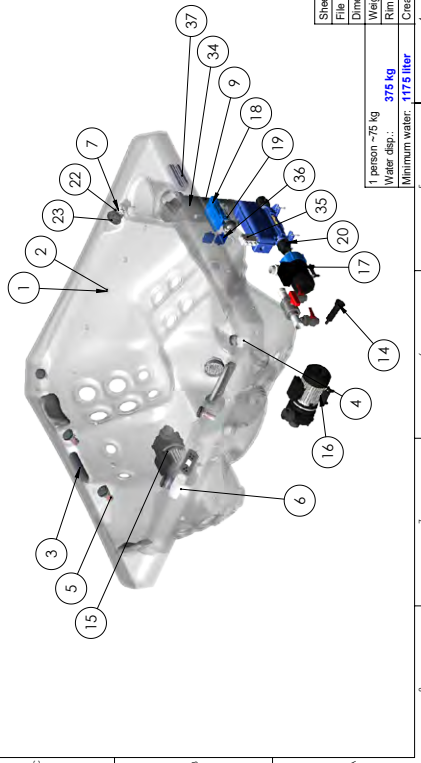
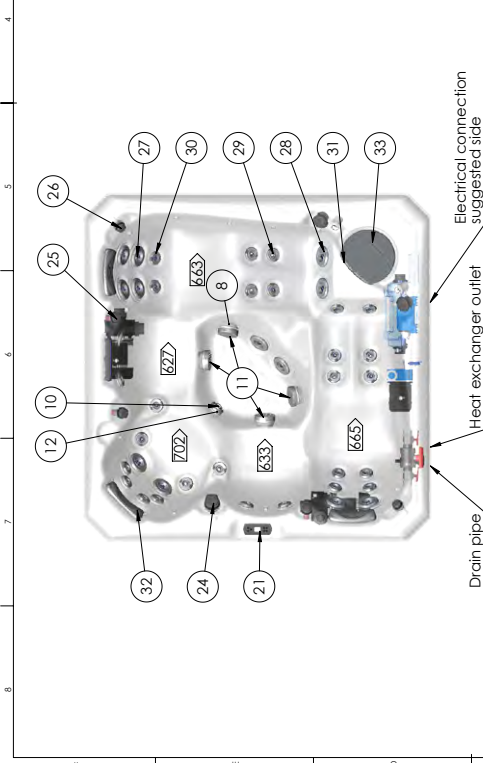
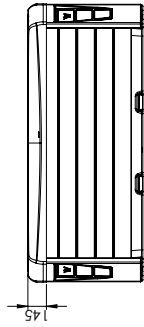

Product family: WelliaCityLife	
Sheet name: Palermo Life spa	File name: E:\M09567_ENG_Palermo Life_mechanics
Dimension SPA: 2180x2160x500 mm	Min E: min. 230 V, 25A - 50Hz / Opt E: needs: 400V - 3x16A - 50Hz
Weight of the SPA: 338 kg	Packing 2200x350 (incl.): AE00382 / Case box Ganco IN VE-3 (IN: 6500 (XAV))
Room height: 145 mm	Approved by: Rest Tamas / Part No. Number: WM00567
Created: 2024. 04. 17.	Drawer: rest.tamas - 2024. 04. 17. 11:09:28
	AS 1 M 1.20

Person: ~75 kg	Water disp.: ~1175 liter
Minimum water:	

CONNECTION DIAGRAM

MANHATTAN LIFE

No.	Art. No.	Part Name	Part No.
1	AKU1892	Air Regulator - In-line neiglight V2	1
2	AKU1893	On-Off tap house 3S transparent V2	3
3	AKU1891	Water Diverter 60 - LED lighted V2	1
4	AKU2625	Fountain hornor V3	F
5	A4B3505	Beckhoff 14x2" Icon (magnet) from lease V2	2
6	AKU2647	Face housing with seal	10
7	AKU2219	Nut for enclosure	10
8	AKU1830	Filter house for flooding 50 sqd filters	1
9	AJU0291	Jet ozone with sealing V2	1
10	AJU0282	Jet water circulation selfwetting medium gray for life	1
11	AKU0084	Water Drain - 20.8A V2	E
12	AKU0380	50s Ramp 3 HP - One Speed	1
13	AKU0886	Circulation pump WFC300/250 W 0.33 hp	1
14	AKM0755	Control box in TE-3	1
15	A4B3501	Ozon mixer - housing	1
16	A4B3500	Mixer housing	1
17	AKM0874	Speaker 3" (2 way)	2
18	AKM0875	Gate for speaker 3" (2 way)	2
19	AKM0859	Control Panel - IN4500 GECKO	1
20	AJU0214	Jet 2" - transparent - Hole transparent V3 Walls	2
21	AJU0216	Jet 3" - transparent - Hole V3 Walls	20 D
22	AJU0217	Jet 3" - transparent - Hole Rotation transparent V3 Walls	6
23	AJU0218	Jet 5" - transparent - Hole transparent V3 Walls	2
24	AKU1832	Filter house - Stemmer Cover round	1
25	AKU1842	Stemmer house with Walls logo	1
26	AF00061	Pilew 300X24654 white ribbed	3
27	AKU1895	Air regulator grid Walls V2	3
28	AKU1896	On-off tap grip Walls V2	1
29	AKU0843	Amplifier Bluetooth for Stemmer 2.0 Sound System	1 C
30	AKM0961	Land Control box	1
31	AKM0901	Wifi receiver in touch 2 Gecko E164K	1

You must install a 30 mA residual-current device (RCD).

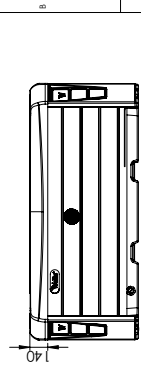

Product family: WellaChyLife	
Project no: EN	
Sheet name: Manhattan Life spa	
File name: EJ_WM0772_ENG_Manhattan Life spa.docx	File no: 3x164 - 5R12
Dimension SPA: 2010x1650x850 mm	Min. El. units: 230 V - 20A - 50Hz / Opt. El. needs: 140V - 3x164 - 5R12
Weight of the SPA: 242 kg	Package: 165x65 - AEG0090
Min height: 140 mm	Approved by: Rest Tamas
Created: 2024. 04. 17.	Drawer: rest.tamas - 2024. 04. 17. 10:37:30
Number: WM00773	Page: 1/2

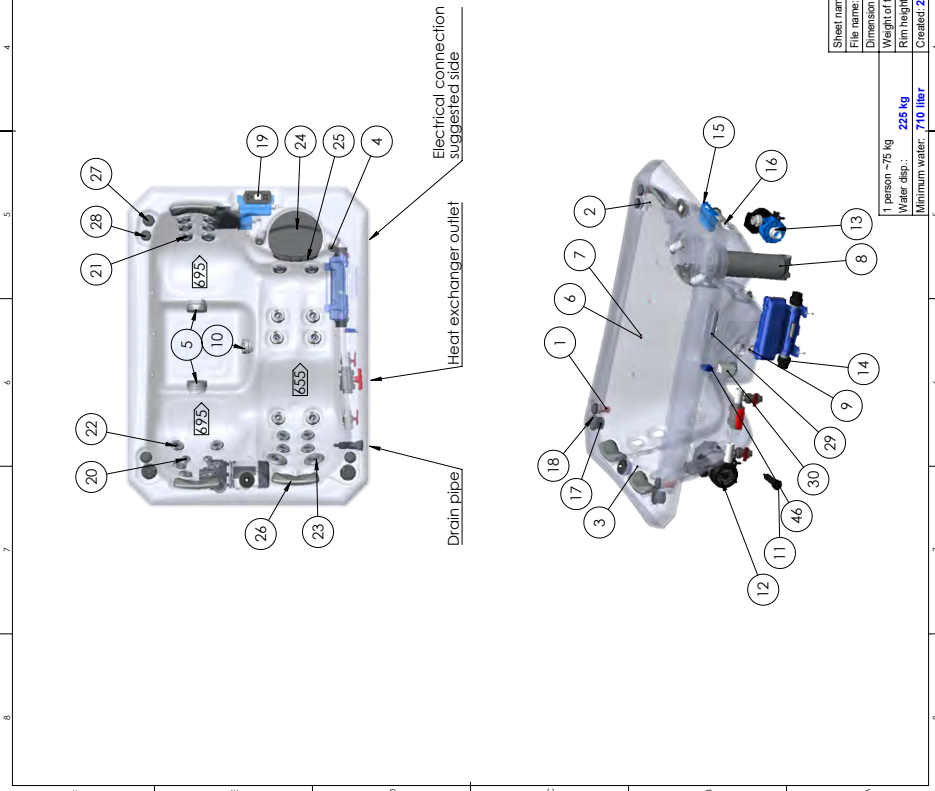

Person: -75 kg
Water disp.: 225 kg
Minimum water: 710 liter

CONNECTION DIAGRAM

VIENNA LIFE

No.	Art. No.	Part Name
1	AKU1892	Air Regulator - house led/light V2
2	AKU0056	Cup Holder Light lens light blue/transparent
3	AKU2447	LED housing with seal
4	AKU2219	Nut for hotchouse
5	AKU2471	Washer LED light led stainless steel
6	AKU1893	Ch-off top house 3/8 transparent V2
7	AKU0291	Jet ozone with sealing V2
8	AAJ0292	Ozone nut seal-odging V2
9	AKU1891	Water Diverter 60 - LED lighted V2
10	AKR0555	Beer/soft/hot 27 x 6cm (meagel) NonMetal V2
11	AK0290	Self capting nut for suction head life
12	AAJ0292	Jet water circulation self-leveling medium grey for life
13	AAJ0293	Circulation jet nut self-captng 48 life
14	AKU0084	Water Drain - 20.8 B V2
15	AKU0084	Circulation pump WFC30M 250 W 0.33 Hp
16	AKC0086	Stop pump 3 HP - Ona sealed
17	AKR0556	Self Valve 48
18	AKR0550	tee 48-32
19	AKR0308	Cham mixer - Houring
20	AKR0301	Water housing
21	AKR0303	Control Box N1-E3 Gecko (SKW) V3
22	AKC0087	Screen 3" (2 way)
23	AKC0087	Galle for speaker 3" (2 way)
24	AKC0085	Control Panel - INLS500 GECKO
25	AKC0089	Jet 3" - transparent 1 Hole V3 Wells
26	AKC0216	Jet 2" - transparent 1 Hole transparent V3 Wells
27	AKC0214	Jet 1.5" - 1.5" - 1.52" - Wells Antimicrobial Blue (line filter)
28	AKU0136	Air regulator grip Wells V2
29	AKU1895	Water Diverter - Grip Wells V2
30	AKU1894	Ch-off top grip Wells V2
31	AKU1896	Ch-off top house 3/8 transparent V2
32	AKU1833	Filter House - Slimmer Cover grey with Wells logo
33	AKC0065	Flow 42017 grey (RCB) light grey
34	AKU1835	Slimmer house light grey

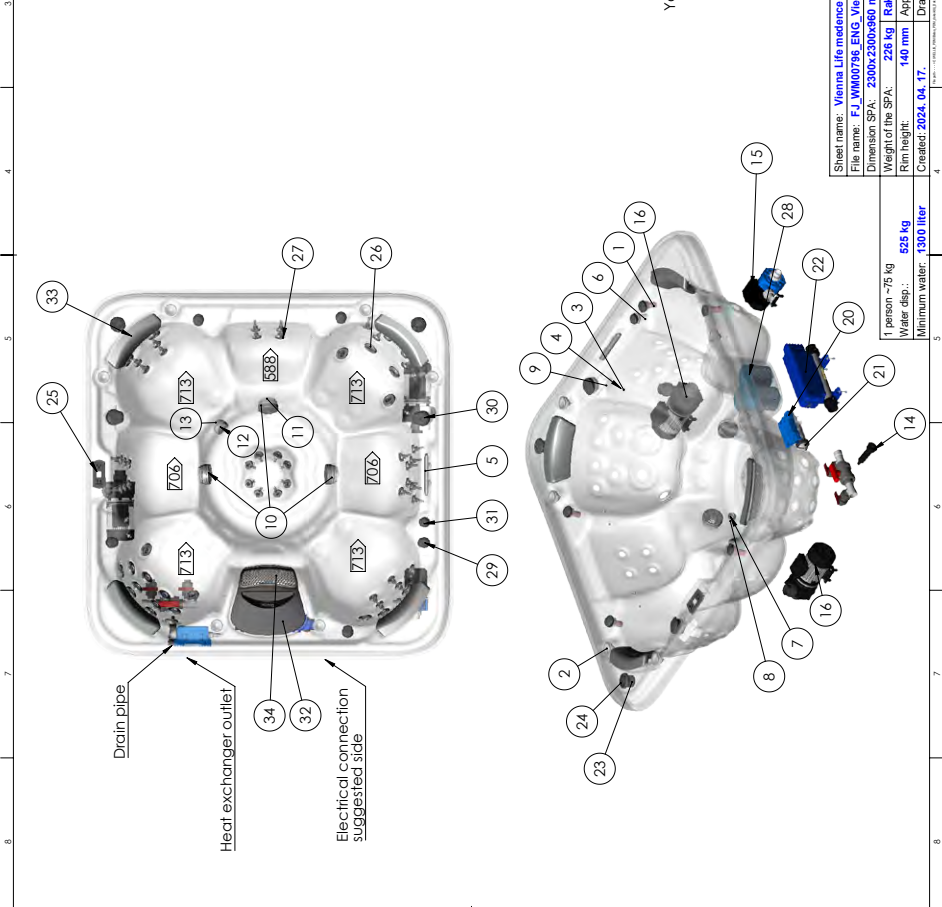

You must install a 30 mA residual-current device (RCD).

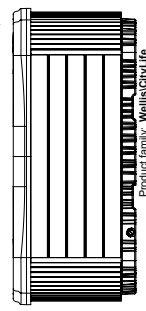

Sheet name: Vienna Life medicine	
File name: EI_WM00796_ENG_Vienna_Life_medicine	Project no: 65
Dimension: SPA - 2300x2300x560 mm	Min. EI ins: 230 V - 25A - 50Hz / Opt. EI ins: 400V - 3x16A - 50Hz
Weight of the SPA: 228 kg	Packing: 233x238 - A1C03423
Net weight: 140 mm	Approved by: Rest Tamas
Created: 2024. 04. 17.	Drawn: rest.tamas - 2024. 04. 17. 10:46:03
Minimum water: 1300 liter	Water disp.: 625 kg
	Water disp.: 625 kg
	Number: WM00796
	AS 1 M 1.20
	page 1/2

CONNECTION DIAGRAM

BUDAPEST LIFE

Item	Code	Description	Quantity
1	AU0247	IR5 transformer EN	1
2	AU0247	IR5 transformer with seal	1
3	AU0259	Water heating with seal	1
4	AU0259	Water heating with seal	1
5	AU0182	Water diverter with seal	1
6	AU0182	Water diverter with seal	1
7	AU0182	Water diverter with seal	1
8	AU0182	Water diverter with seal	1
9	AU0182	Water diverter with seal	1
10	AU0182	Water diverter with seal	1
11	AU0182	Water diverter with seal	1
12	AU0182	Water diverter with seal	1
13	AU0182	Water diverter with seal	1
14	AU0182	Water diverter with seal	1
15	AU0182	Water diverter with seal	1
16	AU0182	Water diverter with seal	1
17	AU0182	Water diverter with seal	1
18	AU0182	Water diverter with seal	1
19	AU0182	Water diverter with seal	1
20	AU0182	Water diverter with seal	1
21	AU0182	Water diverter with seal	1
22	AU0182	Water diverter with seal	1
23	AU0182	Water diverter with seal	1
24	AU0182	Water diverter with seal	1
25	AU0182	Water diverter with seal	1
26	AU0182	Water diverter with seal	1
27	AU0182	Water diverter with seal	1
28	AU0182	Water diverter with seal	1
29	AU0182	Water diverter with seal	1
30	AU0182	Water diverter with seal	1
31	AU0182	Water diverter with seal	1
32	AU0182	Water diverter with seal	1
33	AU0182	Water diverter with seal	1

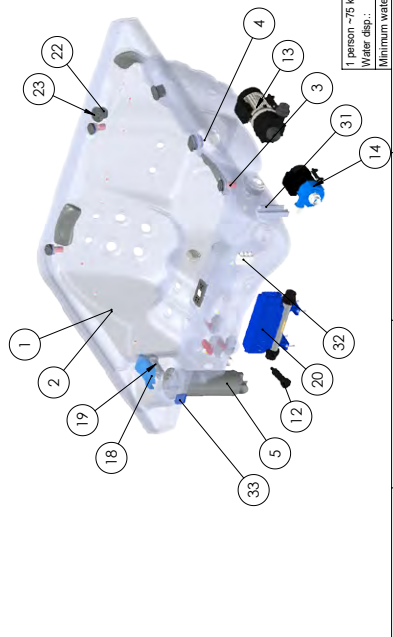

You must install a 30 mA residual-current device (RCD).

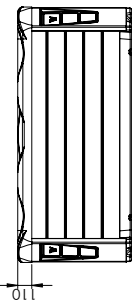

Sheet name: Budapest Life spa	
File name: E1_WW00759_ENG_Budapest_Life_products	Product family: WelltoCityLife
Dimension SPA: 2000x2600x800 mm	Min. EI: ins: 230 V - 20A - 50Hz / Opt. EI: needs: 400V - 3x16A - 50Hz
Weight of the SPA: 239 kg	Control box: GEORGIN VES 2 (KX7-KX8) - [EN]
Rem height: 110 mm	Approved by: Rest Family
Created: 2024. 04. 23.	Drawer: rest.family - 2024. 04. 23. 8:28:30
1 person - 75 kg	Number: WW00759
Water disp. ...	AS 1 M 1:20
Minimum water: 1200 liter	page 1/2

CONNECTION DIAGRAM

PRAGUE LIFE

No.	Art. No.	Description	QTY
1	AGU1893	On-Off top housing 33 transparent V2	1
2	AGU2437	Cup holder light - lens white 2020	2
3	AGU2438	Cup holder light - nut	2
4	AGU1830	Filter house for flocculating 50 µm filters	1
5	ABE5005	Bezávějeř (náz. 7' křom) (modul) (komplekt V2)	3
6	AJAJ0291	J-El ozone with sealing V2	1
7	AGU1891	Water Diverter 60 - LED lighted V2	1
8	AGU1892	Air Regulator - house rec lighted V2	4
9	AJAJ0292	J-El water circulation refilling medium gray for file	1
10	AGU0084	Water Drain - 20 RB V2	1
11	ACM0080	Spa Pump 3 HP - One Speed	1
12	ACM0084	Circulation pump WC 50M 250 W 0.33 Hp	1
13	ABE0501	Ozon mixer - Housing	1
14	ABE0500	Mixer housing	1
15	ACM0059	Control Panel - IN 5000 GECKO	1
16	ACM0074	Staircase 2 (P. woxi)	1
17	ACM0214	J-El 2" - transparent 1 Hole transparent V3 Wells	30
18	ACM0214	J-El 3" - transparent 1 Hole rotation transparent V3 Wells	4
19	AGU1830	Filter house - aluminum 50 µm with 1000 µm coarse round	1
20	AGU1832	Filter house - aluminum 50 µm with 1000 µm coarse round	1
21	ACM0295	Gate for speaker 3" (P. woxi)	2
22	AGU1895	One-off trap cap Wells V2	2
23	AGU1895	Air regulator cap Wells V2	4
24	AGU1894	Water Diverter - Cap Wells V2	1
25	ARD0061	Flow 3000 24x54 white ribbed	3
26	ACM1051	Control box IN YES3 Gecko BK w/ V3	1
27	AGU2647	LED housing with led	15
28	AGU2219	Nut for flashlight	15
29	ARD0045	pillow holder	2
30	AGU2697	Underwater light housing	1
31	AJAJ0290	Self adjusting nut for suction head life	3
32	AJAJ0216	J-El 3" - transparent 1 Hole V3 Wells	12
33	AJAJ0219	J-El 5" - transparent 1 Hole rotation transparent V3 Wells	4
34	AGU0098	Flow Holder - 17	1
35	ACM0081	Control Panel - IN 5000 GECKO	1
36	ACM0090	WGS control panel - IN 5000 GECKO	1
37	ACM0093	Accepter Bluetooth for Staircase 2 (5 Sound System)	1

You must install a 30 mA residual-current device (RCD).

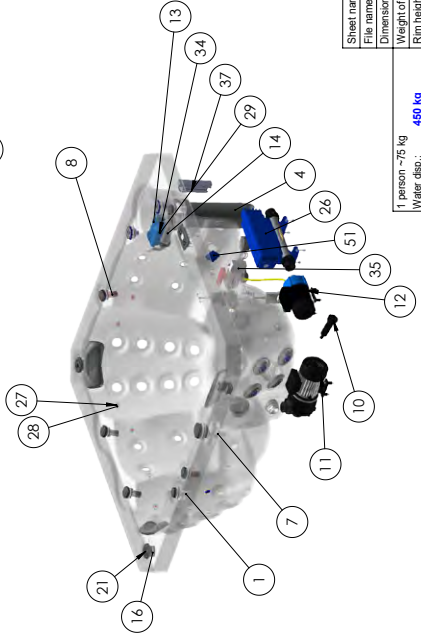
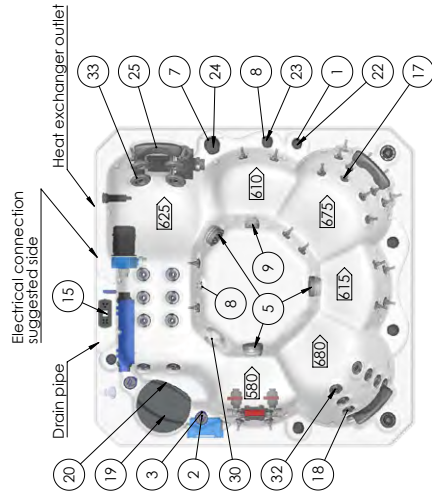
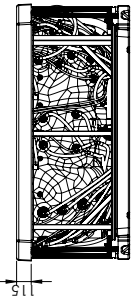

Sheet name: Prague Life spa		Product family: WellaCityLife	
File name: EL 14060800 ENG Prague Life_maintenance		Project no: 14060800	
Dimension SPA: 2000x2000x850 mm	Min. El. ins: 230 V - 20A - 50Hz	Opt. El. ins: 400V - 3x16A - 50Hz	WellaCityLife
Weight of the SPA: 280 kg	Package - AE0093	Control box: GECKO IN YES 3 Y 500 - 3NXP	
Room height: 115 mm	Approved by: Rest Tams	Number: WNU0080	
Created: 2024. 04. 17.	Drawer: rest.tams@wella.com - 2024. 04. 17. 10:25:42	AS 1 M 1:20	page 1/2

1 person - 75 kg
Water disp... 1200 liter
Minimum water:

CONNECTION DIAGRAM

FIRENZE LIFE

No.	Art. No.	Art. Name
1	AJ018972	Air Regulator - house led lighted V2
2	AJ02847	led housing with seal
3	AJ02219	Nut for respouse
4	AJ01891	Water Diverter 60 - LED lighted V2
5	AJ01077	Filter house - wall one filter
6	AJ05055	Suction 2' chrome thick with seal V2
7	AJ00291	Jet nozzles with sealing V2
8	AJ00287	
9	AJ00284	Water Drain - 20 RB V2
10	AJ003594	300 Pump 29/047 HP - two speed
11	AJ00846	Circulation pump WYCS30W 250 W 0.35 Hp
12	AJ00997	Heater - 3000 W
13	AJ05021	Overmixer -housing
14	AJ05020	Overmixer
15	AJ05022	Overmixer P54 100 mA
16	AJ00979	Control Panel 11/3200 - One Pump
17	AJ00979	Control Panel 11/3200 - One Pump
18	AJ00874	Speaker 3" (2 way)
19	AJ00875	Grilles for speaker 3" (2 way)
20	AJ00217	Jet 3" - transparent Hole Rotation transparent V3 Wells V2
21	AJ00216	Jet 3" - transparent Hole V3 Wells
22	AJ00214	Jet 2" - transparent Hole transparent V3 Wells
23	AJ01894	Water Diverter - Grip Wells V2
24	AJ01895	Air regulator grip Wells V2
25	AJ00362	Flow 2500 145x85 light grey

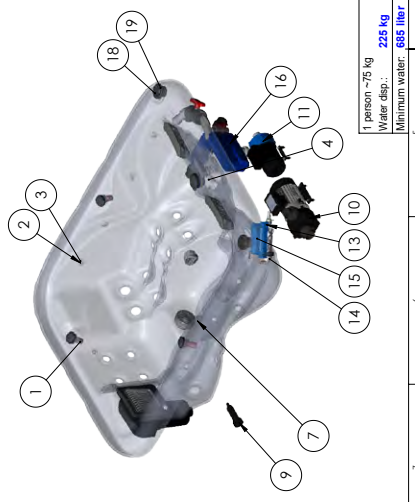
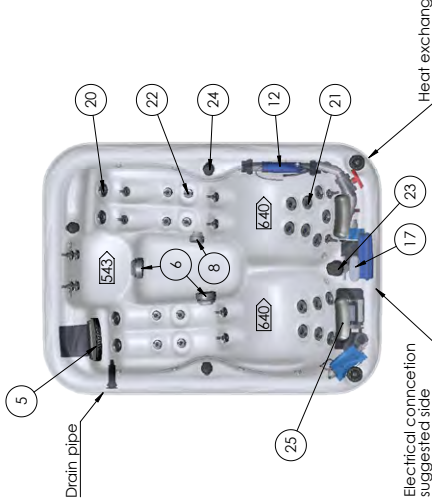

You must install a 30 mA residual-current device (RCD).

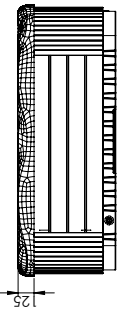

Sheet name: Firenze Life app File name: FI_WW00552 ENG_Firenze_Life_madeinusa Dimension SPA: 1600x2150x750 mm Min. El. ins. 230 V - 16A - 50Hz Opt. El. needs: 230V - 25A - 50Hz Weight of the SPA: 178 kg Packing 1650x340 - A000899 Rem height: 725 mm Approved by: Customer Sandler Created: 2023. 02. 24. Drawer: bestemmer.sandler - 2023. 02. 24. 12:08:44 AS IM 1:20 page 1/2	
1 person ~75 kg Water disp.: 225 liter Minimum water: 685 liter	Product family: WellisCityLife Project code:

INITIAL INSTALLATION

Electrical preparations:

A clearly labeled emergency switch shall be provided as part of the installation. The switch shall be readily accessible to the occupants and shall be installed at least 5 feet (1.52 m) away, adjacent to, and within sight of, the unit.

Before installation the hot tub, the electrical system has to be prepared, as detailed in the below table.

Item number	Spa name	Requirements	Heater (w)	Water quantity (litre)	Dry weight (kg)	Filled weight (kg)	Dead weight (kg/m ²)	Dimensions		High	Filter (sqf)
WM00541	Malaga Life	min: 230V/1x35A/50Hz opt: 400V/3x22/50Hz	3000	1200	335	1535	323	2180 mm	2180 mm	900 mm	1x50
WM00564	Lima Life	min: 230V/1x25A/50Hz opt: 400V/3x16A/50Hz	3000	1300	335	1635	345	2180 mm	2180 mm	900 mm	1x50
WM00567	Palermo Life	min: 230V/1x35A/50Hz opt: 400V/3x22/50Hz	3000	1175	335	1510	318	2180 mm	2180 mm	900 mm	1x50
WM00723	Lugano Life	min: 230V/1x35A/50Hz opt: 400V/3x22/50Hz	3000	1600	387	1987	376	2300 mm	2300 mm	940 mm	3x30
WM00773	Manhattan Life	1X32A/230V/50HZ min: 1x16 A/230V/50HZ	3000	280	560	840	274	2010 mm	1530 mm	850 mm	1x50
WM00796	Vienna Life	22A /35A - 230V/50HZ	3000	1300	226	1526	289	2300 mm	2300 mm	960 mm	1x50
WM00799	Budapest Life	min: 230V/1x22A/50Hz opt.: 230V/1x35A/50Hz	3000	1100	236	1336	334	2000 mm	2000 mm	890 mm	1x50
WM00800	Prague Life	min: 230V/1x16A/50Hz opt: 230V/1x25/50Hz	3000	1200	226	1426	357	2000 mm	2000 mm	900 mm	1x50
WM00552	Firenze Life	min: 230V/1x16A/50Hz opt: 230V/1x25/50Hz	3000	685	175	860	225	1600 mm	2130 mm	750 mm	1x50

INITIAL INSTALLATION

SITE PREPARATION

When choosing a site for the hot tub take into account that its maintenance and repair works must be carried out behind the sidewalls, so accessibility and hot tubce to walk around the hot tub must be ensured.

1. INDOOR/BASEMENT INSTALLATION

If you place your hot tub indoors, be aware of some special requirements:

Water may accumulate around the hot tub, so the flooring material must have a proper runoff to avoid accumulation of water. When building a new room for the hot tub, constructing a floor drain is required, or damages may occur due to overflow, overfilling, or technical failure. Our company does not take responsibility for any damage in absence of floor drainage. Humidity will naturally increase in the room where the hot tub is located and the evaporated water condenses. For this reason ensure that the area has proper ventilation. We recommend installing a dehumidifier in the room.

2. OUTDOOR AND PATIO INSTALLATION

A solid horizontal foundation is necessary for installation of the hot tub. We advise using a reinforced concrete foundation at least 10-15cm thick. Do not shim the spa, it may casue not repairable damages. The base to be even and horizontal.



Ensure that your deck or foundation will support your hot tub. You must know the maximal load capacity of the foundation. Consult a qualified building contractor or structural engineer.

To find out the weight of your hot tub, its contents and occupants please refer to the hot tub specification chart. This weight must not exceed the structure's rated capacity per square meter, otherwise serious structural damages could result. If you install the hot tub outdoors, we recommend a reinforced horizontal concrete pad at least 10-15cm thick.

Install floor drains around your hot tub to lead water away even in heavy rain.

When constructing the water drain it is advised to form a 10-15cm deep sloping ditch around the hot tub which directs water to the drain. Water from the drain must be directed to the canal or a drainage with enough capacity.

Warning: Do not expose the hot tub to direct sunlight (not even empty) without proper coverage. The insulated hot tub cover preserves the water temperature and provides protection from sunlight and rain. When exposed to sunshine for a longer period it may damage the surface of the hot tub and the hot tub equipment.

Acrylic rapidly absorbs heat from sun rays, thus reaches a very high surface temperature which may damage the hot tub.

In case of sealed design, if the hot tub was placed between glass structures, prevent the sun rays from reaching the hot tub directly through the glass as the temperature may get too high.

3. IN-GROUND / SUNKEN HOT TUB

In case of sinking the hot tub into the ground you must make sufficient space for walking around the hot tub. For completion of maintenance works a minimum of 60cm wide inspection pit must be built around the hot tub.

The inspection pit's bottom must be under the bearing point of the hot tub so that water can flow into the pit in case of water leakage. A floor drain or sump pump should be used at the bottom of the pit to ensure continual water drainage.

In case of sinking the hot tub only the portion below the hot tub's acrylic edge can be sunk. The air of the inspection pit steams up. To prevent unpleasant odors proper ventilation must be provided (e.g. installing ventilators). The costs of pulling the hot tub out of the ground are borne by the user. If the aforementioned conditions are not present, setting up the hot tub may fail.

First filling of the hot tub

Proper filling of the hot tub is an important task both technically and chemically. We advise installation and periodic maintenance by the servicing professionals, which includes inspection and refilling of hot tub water. Hot tubs do not contain water softener and hard water damages the equipment. Improper filling of the hot tub may bring air into the system, which damages the heating wire and engines. Repairs after such failures are not covered by warranty.

INITIAL INSTALLATION

Filling process

Remove the hot tub cover. First remove the cover staves, then remove the side covers by unscrewing the bottom screws. During transportation the flare fittings of engines may dislocate. Check these connections before installation. If necessary, tighten the flare fittings.

Before filling the hot tub check that the Slice valves are not in a closed state (lever is pulled out and fixed with the safety lock).

Next fill the hot tub with water to the sign indicated on its sidewall.

Filling must be done through the filter housing. Improper filling can damage the engines and heating element.

Insert the filter or filter cartridges when proper water level is reached. Be cautious, because when replacing the filter cartridge air bubbles may remain in the cartridge. To avoid this the filter cartridges must be tilted in the water to remove air from them, and only then fitted to their place.



INITIAL INSTALLATION

IONIC EXCHANGE WATER SOFTENER AND CARBON FILTER

For the optimal quality the following steps shall be followed during the usage:

1.

Please check the required water volume in the manual of the spa or contact our customer service for help. The exact volume is needed for the precise filling.

2.

Please remove the covering caps from both ends to connect the filling hose.



3.

Please connect the carbon filter to the water hose via the screw thread gasket (included with the filter).



4.

Please run water through the filter into a separate vessel until it becomes perfectly clear. This step allows the filter to rinse from the remaining carbon powder. The rinse cycle lasts for 30 seconds at most with approx 10 litres of water.



0'-30'



>30'

5.

Through the clean filter fill up the spa with one third (1/3) of the total volume (e.g.: with 1000 litres of total volume 1/3 is 300 litres). It is important to follow the instructions of the filling for it is crucial to set the precise water hardness.



Insert the filter or filter cartridges when proper water level is reached. Be cautious, because when replacing the filter cartridge air bubbles may remain in the cartridge. To avoid this the filter cartridges must be tilted in the water to remove air from them, and only then fitted to their place.

6.

After the filling please remove the caps from the water softener cartridge too and connect it with the carbon filter. With water softener the rinsing is significantly faster, so only this first 1 liter needs to be drained separately!

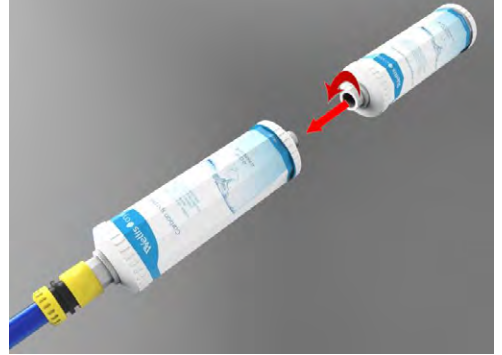

7.

Please check the water hardness during the filling with the softener. There are multiple choice of using a hardness tester. Testers sold by Wellis are showing the hardness level on a colour scale.

If the value shown is less than the optimal value the water will create foam during the usage, if the value is more that will cause limescaling.



8.

If the water hardness is extremely low during the filling please remove the softener cartridge and continue the filling with only the carbon filter as it shown at point 5.

MAINTENANCE

FILTER CARTRIDGE REMOVAL AND CLEANING

Cleaning mechanical contaminations via continuous water circulation and chemical mixture is a basic requirement for proper cleaning of the spa water. Every spa has an engine designed for this purpose. The circulation engine circulates the water through the filter(s). The filter protects against contamination floating in the water.

Cleaning of the filter cartridges is recommended weekly.

Soaking the filter cartridges in water mixed with chlorine or antialgae agents for 24 hours is recommended monthly.

Changing the filter cartridges is necessary every 3 months.

SURFACE MAINTENANCE

Wipe the surface with a wet cloth. Always use a neutral cleaning product and a soft wiping cloth. Never scratch the acrylic surface with an abrasive tool, blade, or knife, because it may cause damage. Never use nail polish remover, acetone, or paint stripper when cleaning the surface because it may cause damage.

Maintenance manual for the control panel of the spa:

- Do not damage the control panel with anything hard. If possible,
- Avoid exposing the control panel to direct sunlight.
- When not using the spa, always use a spa cover.

WINTERIZATION

Remember to correctly maintain the spa if you are not using it in the winter. If you are not using your spa during the winter months and want to put it out of service properly, call one of our qualified professionals to winterize your spa at a prearranged date and time.

The winterization encompasses the following:

- Drainage of used water
- Cleaning of the inner surface of the spa
- Dewatering of pipe and jet system
- Dewatering and disconnecting the engine's interface
- Delivery - reception

If the spa is not winterized properly, the system can retain water that can easily freeze during the winter months. This can cause heavy irreparable damage to the pipes and the engine. This will void the warranty.

Maintenance of the out-of-service spa:

When you are not using the spa, use the thermo cover and fasten it with the buckles. Do not forget! If the spa is filled with water and you are not using it, lift the cover at least once a week to ensure proper ventilation. The thermo cover is multipurpose. Most importantly it decreases the heating time of the water to operational temperature and decreases the energy needed to maintain water temperature, decreasing the operational costs.

Using the cover you can avoid leaves, rain, snow, or other contamination entering the spa water, effectively sealing it off from environmental effects.

Fastening the cover with buckles prevents young children from using it without parental supervision.

CLEAN THE FILTER CARTRIDGES WEEKLY AS FOLLOWS:

WARNING!

Changing the filter cartridges is recommended every 3 months!

Operating the spa without a filter cartridge is PROHIBITED

1. Remove the lid of the filter.
2. Take out the filter cartridge.
3. Clean contamination from the cartridge with water.
4. Soak the cartridge in lukewarm water mixed with chlorine or antialgae agents for 1-2 hours, then rinse it.

Never use an alkaline detergent or a high-pressure cleaner to clean the filter!



DRAINING THE WATER

You can drain the water via the drain outlet in accordance with environmental standards.

1. You'll need a hose a wet and dry vacuum cleaner and a bottle of wellis crystal spa cleaner fluid.
2. Pour the cleaner fluid into the water one day before draining and run the open jets at maximum performance for 20 to 25 minutes. The cleaner will remove any lime scale and dirt from the spa and its pipe work.
3. Before draining the spa remove the filters, this is a good time for cleaning or replacing them.
4. You don't need a pump for draining the water pull out the draining valve to the limit.
5. Remove the cap and attach the hose.
6. Push back the valve halfway then rotate and secure it in this position, this will start the flow of water. We recommend rinsing the tub while it drains
7. When the tub is empty remove the hose and close the valve.
8. Use a wet and dry vacuum to clean up any remaining water from the spa and the jet nozzles.

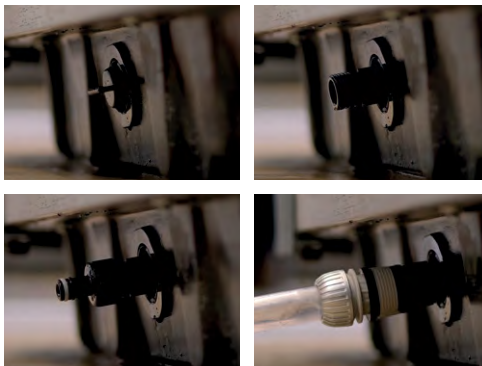

SPA CHEMICAL TREATMENT

SPA CLEANER (WV00080)

Spa Cleaner has been specially designed for cleaning your pipes and your spa pool. It dissolves calcium and remaining dirt in your lines. We advise to use Spa Cleaner every time you change the water, we recommend to do this every three months. Spa Cleaner is environmentally friendly and bio-degradable.

Instructions:

1. Add 250 ml of Spa Cleaner to your spa, 24 hours before changing the water.
2. Make sure all jets and valves are open, and switch on the pumps at full power for 15 minutes. Repeat this 3 times, with enough time in between.
3. Remove the filter before you drain your spa water.
4. Clean the filter with Wellis Crystal Filter cleaner.
5. Rinse out the spa with clean water.
6. Fill your spa and place the clean filter back.
7. Resume your normal water treatment schedule with Wellis Crystal All in one Water treatment.



ALKALINITY BALANCER (WV00091)

Increases total alkalinity and prevents fluctuating pH values. Alkalinity is important to be able to check the pH value.

Instructions:

1. Shake well before use
2. Add 1 or 2 tablespoons of Alkalinity Balancer to the spa water
3. Put your pumps on circulation for at least 30 minutes
4. Test the alkalinity value again and repeat the treatment until the alkalinity value is between 80 and 120 ppm



BRIGHT AND CLEAR (WV00090)

For neutralizing dirt, soap, oil in all spas. When added regularly, ensures crystal clear water.

Instructions:

1. Add 100ml into the spa. Pour product directly into the spa and run the filter system for 1 hour.
2. Rinse the filter unit.
3. Put the filter back and enjoy your spa!



SPA CHEMICAL TREATMENT

FOAM DOWN (WV00093)

Anti-foam product for use in spas. Contains no oily substances. Designed for hot water applications.

Instructions:

1. Shake well before use.
2. Spray undiluted to the foam.
3. Repeat step two if needed.
4. Enjoy your spa!



PH MINUS (WV00096)

The pH value of the water in your spa is very important. If the pH value is good, the disinfection products can do their work in a good way. Wellis Crystal pH Minus lowers the pH in your spa.

Instructions:

1. Test the pH of your spa
2. If the PH is too high, adjust it with pH Minus.
3. Add 2 ml pH- per 1000 liter water, in order to decrease the pH value with 0.1 point.

METAL CLEAR (WV00094)

Prevents the accumulation of deposits on the metal components of the spa's nozzles. Interacts with metallic contamination before it can cause invisible deposits in your spa. Neutralizes iron, copper, and other water-bound minerals and keeps them from accumulating on the spa's surfaces and causing damage there.

Use whenever you fill your spa to quickly neutralize metals and prevent unsightly staining.

Features:

- Prevents iron, copper, and other minerals from accumulating in the spa.
- Use whenever you exchange the spa's water to quickly neutralize metals and prevent deposits.
- Only use when the entire spa water is being exchanged - the product is of high concentration.

Instructions:

- Interval: whenever the spa is being (re-)filled.
- Evenly spread 250 ml of Metal Clear in the spa.
- Run the filter system for 30 minutes.



SPA CHEMICAL TREATMENT

FILTER CLEANER (WV00079)

If you clean the filter once a week, it is easier to keep the water crystal clear.

Instructions:

1. Take the filter out of your spas filter housing.
2. Fill a bucket with 10 liter hot water, put 2 scoops of Filter cleaner in and leave the filter in this solution for 1-1.5 hours (turn the filters during this process).
3. Rinse the filter, and put it back in its place.



WELLIS CRYSTAL ALL-IN-ONE (WV00081)

Instructions:

- Shake the Wellis Crystal bottle well.
- Add the correct amount to your spa using the table below.
- Let the pump run at full power for 2 minutes.
- Add your disinfectant, for example 1 90/20 chlorine tablet.
- Repeat these steps weekly.

JET DIRECTIONS

MALAGA LIFE



JET DIRECTIONS

LIMA LIFE



JET DIRECTIONS

PALERMO LIFE



JET DIRECTIONS

LUGANO LIFE



JET DIRECTIONS

MANHATTAN LIFE

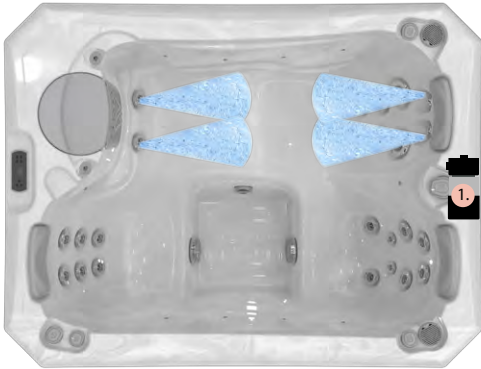
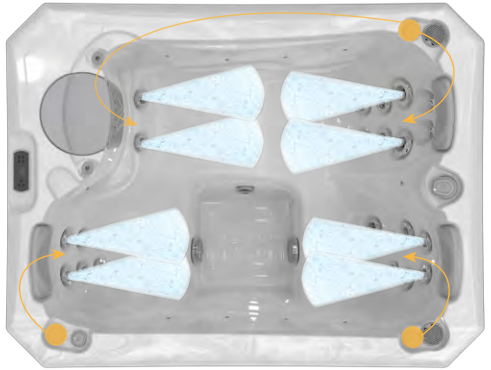
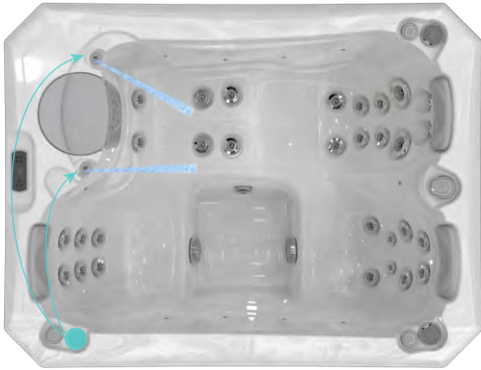

JET DIRECTIONS

VIENNA LIFE



JET DIRECTIONS

BUDAPEST LIFE



JET DIRECTIONS

PRAGUE LIFE

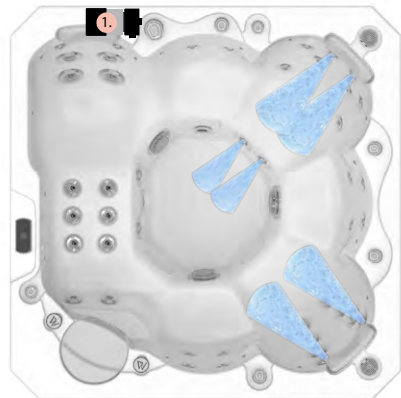
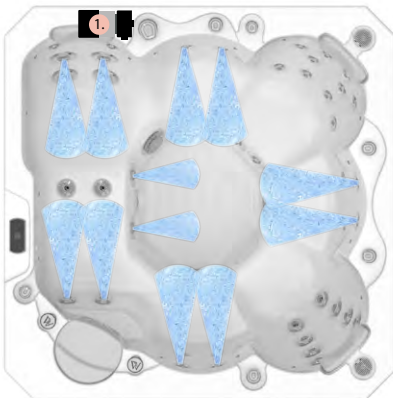
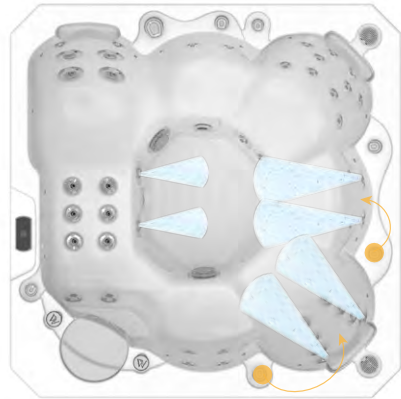
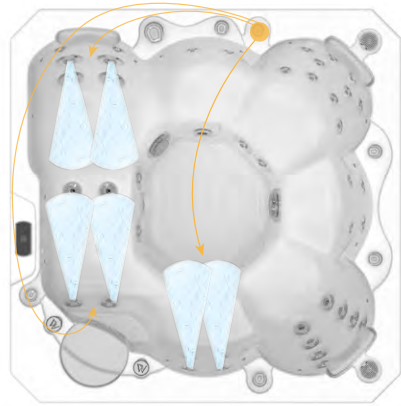

JET DIRECTIONS

FIRENZE LIFE



KEYPAD FUNCTIONS

In.k500 keypad layout

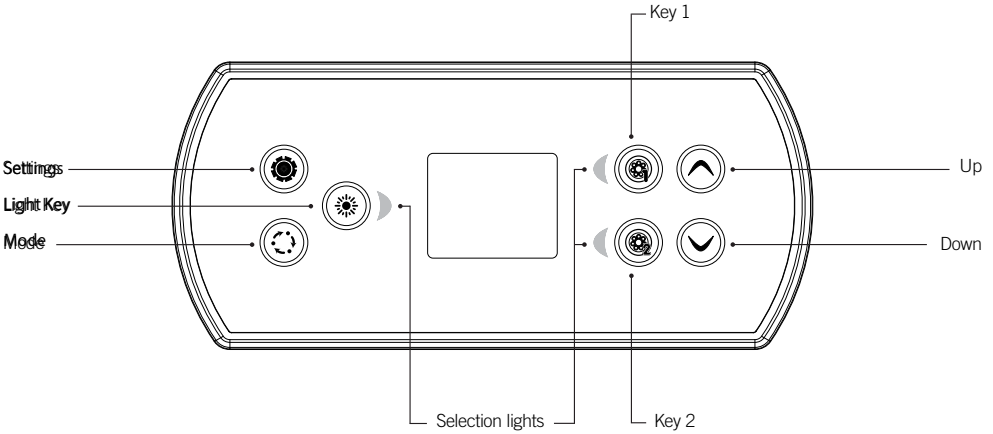

**Functions for keys 1 and 2 will depend on your system's low level configuration.*

Settings key

One press gives you access to a menu to manage the settings of your spa. Refer to the settings section for details about the settings menu.

Mode key

Successive presses on the Mode key will give access to control different optional accessories of your spa such as Audio and others. Note that if an accessory is not present in your spa configuration, its menu will not appear. Refer to the following section to get details about the possible accessories and their detailed functionalities. The screen will revert back to the spa mode if no key is pressed for 60 seconds.

If you don't have any accessories on your spa, the Mode key can be used to directly change your display orientation.



Power

Press any button to turn the keypad on. After 30 minutes without activity it will shut off.

Main screen

The main screen gives you access to your accessories and water temperature. At the bottom of the screen you will see any error or maintenance messages that are present.

KEYPAD FUNCTIONS



Start or stop accessories

To start or stop an accessory, press the associated button. Icons will become animated when their accessory is turned on, and inanimate when turned off. Icons on the screen will reflect the speed or state of the devices running on your spa.

When an accessory has more than two states, press the button until it reaches the desired state.

Note (version 14.00 and higher):

A special buttons and icons mapping may be used when the spa configuration has 4 accessories* (3 pumps and a blower or 4 pumps and no blower). In this case only, buttons and icons are divided in 2 sets of accessories.

Button #1 starts or stops pump #1 and pump #2.

Button #2 starts or stops Pump #3 and Pump #4/blower.

Corresponding icons will be animated when one or more accessories are on.

** Only Pump #1 can have a dual speed.*



Water temperature

The temperature shown at the top of the screen is the current water temperature. Use the Up and Down buttons to set the desired temperature.

The set point will appear in blue at the bottom. After 3 seconds without any change to the set temperature value, the keypad will resume the normal display of messages.

When the set value is lower than the current temperature Cooling to xx.x will appear. When the set value is higher than the current temperature, Heating to xx.x will be indicated. Normally there is a short delay before the heating starts, during which Heating Suspended is indicated.

KEYPAD FUNCTIONS

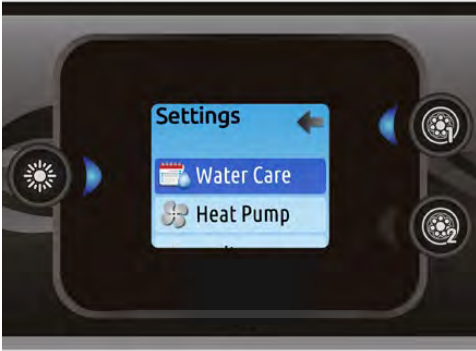

Settings

From the home page you can access the Settings, where you will find:

- *Water care*
- *Heat Pump (if installed)*
- *Audio (if installed)*
- *in.clear-200 (linked version)*
- *Standby*
- *Maintenance*
- *Date & time*
- *Keypad*
- *Wi-Fi*
- *Config*
- *Restore*
- *About*

Use the arrow keys to move up and down in the list.

To select an option, press the lit button beside it (Light button).

At any point you can press the Settings button to return to the home screen.

KEYPAD FUNCTIONS



Water care

The Water Care section will help you set up your ideal filtration and heating settings. Choose from Away, Standard, Energy Savings, Super Energy Savings, and Weekender, depending on your need. Use Light key to choose your setting. A checkmark will appear on the selected icon to confirm.

In Economy mode, the set point will be reduced by 20°F*, which means that the heating system will not be engaged unless the temperature falls to 20°F below the spa's set temperature.

**Default pack value*

Water care modes

Away:



In this mode the spa will always be in economy; the set point will be reduced by 20° F*.

Standard:



The spa will never be in economy mode and will be filtering according to the pack's low level configuration.

Energy Savings:



The spa will be in economy mode during the peak hours of the day and resume normal mode on the weekend*.

Super Energy Savings:



The spa will always be in economy mode during peak hours, every day of the week*.

Weekender:



The spa will be in economy mode from Monday to Friday, and will run normally on the weekend*.

**Filtration will be reduced when the economy mode is active.*

KEYPAD FUNCTIONS



Modifying schedules

To see and/or modify a Water Care category, use the lit button to the right (Key 1) to open the selected Water Care menu.

Use the arrow keys to choose a schedule to modify (choice of economy and filtration schedules). Use the Light key to move between parameters.

You have several possibilities for the schedule (Mon-Fri, weekend, every day, or single days). The schedules will be repeated every week. The time and duration are set in 30 minute increments. Once you have set the schedule, use Key 1 to go back. Ensure that you have selected the desired Water Care option in the main Water Care menu.



The filtration schedule shown on the screen will apply to the main filtration pump, most likely pump 1. If your spa uses a circulation pump configured to run 24 hours, the screen will show you the purge setting instead of filtration. The purges are pre-programmed for a fixed number of minutes, therefore the duration will be set to N/A on the screen, and only the start time can be modified.

KEYPAD FUNCTIONS



Maintenance

From the Settings page you can access the Maintenance menu, which gives you access to the following options:

- *Maintenance reminders*
- *Standby*

Use the Up and Down keys to make a selection, and Light key to confirm.



Maintenance reminders

The in.k500 keypad will remind you of maintenance required on your spa, like rinsing or cleaning the filter. Each task has its own duration, based on normal use.

The Maintenance reminders menu allows you to verify the time left before maintenance is required, as well as to reset the time once a task is completed.

Use the Up and Down keys to move through the list.

To reset a task select it by pressing Light key, then confirm when prompted. Once you have confirmed the task will be reset.



Standby

The Standby mode allows you to service your spa. Pumps will stop for 30 minutes, and automatically restart after this time.

Once Standby mode has been activated a screen will appear to show that pumps are stopped. The normal spa page will return at the end of maintenance.

Press the Key 1 to leave Standby mode and restart the spa.

Note:

In version 6.00 only, Standby mode is accessible directly from the Settings page.

KEYPAD FUNCTIONS

Date and time

Here you can adjust the time format, change the year, date and time. Use the arrows to choose the setting that you want to adjust, and select it by pressing the Light key.

Use the arrow buttons to change the parameters, and the Light key to move between parameters. Key 1 will take you back to the main Settings menu.

Note:

In version 6.00 and earlier, only the day of the week can be changed, and not the year or date.



Keypad settings

In this section, you can change the temperature unit, language, display orientation, rim light color and keypad security. Note the spa pack must be configured accordingly to be able to change the rim light color.

When you change the display orientation, the contextual options and arrow keys adjust to the chosen orientation. If you don't have any accessories installed on your spa, the Mode key can be used as a display orientation key. Simply press on it to change your orientation from normal to inverted, and vice versa.

Whether the display is inverted or not, the Mode and Menu keys remain unchanged, as well as the accessory keys in the main Spa menu.

With the in.k500 equipped with a selectable rim light color modul: If the "RGB backlight" option is enabled in the spa configuration an option will appear to allow selection of the keypad rim light color.

You can lock the keypad by selecting one of 3 security levels: Unlock, Partial or Full. The Partial level locks the set point adjustment and many options in the settings menu. The Full level locks all keypad functions. To unlock the keypad (either Partial or Full), press and hold the Light key for 5 seconds.



KEYPAD FUNCTIONS



WiFi (in.touch only)

For the WiFi menu to appear in the Settings menu your in.touch module must be equipped with software version 11.00 or higher. This menu allows you to connect your in.touch module to a WiFi network or to change its network.

For more details about other in.touch connection methods please see the in.touch techbook.

To connect your in.touch module to a wireless network, use the Up/Down keys to go to the WiFi option in the Settings menu and Light key to select it.

After a few seconds the available networks will appear on the screen, as well as their signal strength.

Use the Up/Down keys to move through the list. Select your network by pressing on Light key.

If the WiFi network is password protected enter it when prompted.

- Use the arrow keys to choose your letters and change the type of character (uppercase, lowercase, number, symbol).
- Use Key 2 to move the cursor forward
- Use Key 1 to backspace
- Use Light key to confirm

If no password is required the in.touch will connect automatically.



Once the in.touch module is connected to a WiFi network a check mark in a green circle will appear in the WiFi menu, and the network logo will change to green in Settings menu.

Note:

WiFi logo color in Settings menu corresponds to the in.touch connection state.

Yellow = not connected

Green = connected to a network

Yellow with wait icon = connection attempt to a network

Red with wait icon = in.touch no longer detected

(in.touch must be reset before next connection attempt)

KEYPAD FUNCTIONS



Config

Please do not make changes in the electrical configuration section unless you are a qualified electrician.

In this section you can change the low-level configuration, number of phases, input current and heat pump current.

Use Up/Down to move between parameters, and the Light key to select a parameter to change. Please refer to the techBook of your specific control system for spa for details about the low level settings.

Once you have changed the Number of Phases in the menu, you will be unable to use the Up/Down keys to return to the Low-level Configuration menu. Please go back and re-enter the Config menu.

Note with version 15.00 and higher:

Depending on the pack configuration, a code may be required to change these settings. This code is "5555".

KEYPAD FUNCTIONS

The list below shows the different error messages that can appear on the home screen.
Refer to the troubleshooting and error codes section of the TechBook for your spa pack system.

Code	Message
HL	Warning! HL Error
FLO - L01	FLO - L02 FLO FLO condition - Check filter, pump, blockage, air lock and water level
NO FLO	Persistent NO FLO, all off - Check filter, pump, blockage, air lock and water level
HR	Danger! Relay stuck
OH	Warning! Spa temp. high
Pr	Warning! Temp. probes defective
AOH	Internal pack temp. high
FLC	Flow switch closed
SP in	Input voltage issue
F1	in.xm2 Fuse # 1 is blown
F2	in.xm2 Fuse # 2 is blown
F3	in.xm2 Fuse # 3 is blown
Hr	Danger! Thermal fuse error
UPL	The spa pack does not have valid software. Please insert valid in.stick to reprogram spa pack.

USER INTERFACE - IN.K300

EASY 4

COMPACT FULL-FUNCTION KEYPAD

The Quick Reference Card provides an overview of your spa's main functions and the operations accessible from your digital keypad. This QRC depicts a generic overlay, custom versions may vary.

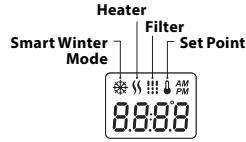

1 PUMP MODEL

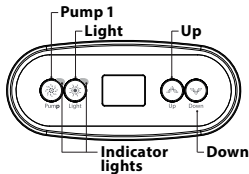

2 PUMP MODEL

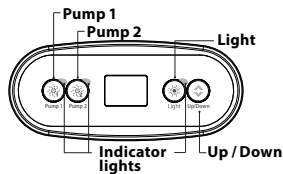

SPA FUNCTIONS



OFF MODE

Pressing Pump 1 for 5 seconds will enable the Off mode. This mode allows you to stop all outputs including automatic functions such as filter cycle, heat request and smart winter mode for 30 minutes to perform quick spa maintenance. When Off mode is active, the display will toggle between the "OFF" message, the clock and the water temperature.

The spa light will flash for a few seconds before the end of the 30 minutes to warn you that the system is about to resume its normal operation. Press Pump 1 or Pump 2 (if available) to restart the system before the expiration of the 30 minute delay. When the system resumes its normal operation, the display shows "On" for 3 seconds.

PUMP 1

Press Pump 1 key to turn Pump 1 on at low speed. Press a second time to turn pump to high speed (with a dual-speed pump*). A third time turns pump off. A built-in timer automatically turns pump off after 20 minutes, unless pump has been manually deactivated first.

The "Pump 1" indicator lights up when Pump 1 is on. With a dual-speed pump, the indicator will flash when pump 1 is on at low speed.



PUMP 2 KEY

Not available on all models
Press Pump 2 key to turn Pump 2 on at low speed. Press a second time to turn pump to high speed (with a dual-speed pump*). A third time turns pump off. A built-in timer automatically turns pump off after 20 minutes, unless pump has been manually deactivated first.

The "Pump 2" indicator lights up when Pump 2 is on. With a dual-speed pump, the indicator will flash when pump 2 is on at low speed.



LIGHT KEY

Press Light key to turn light on. A second press turns light off. A built-in timer automatically turns light off after 2 hours, unless it has been manually deactivated first.

The "Light" indicator lights up when light is on.



UP/DOWN KEYS

Use Up or Down key to set desired water temperature. The temperature setting will be displayed for 2 seconds to confirm your new selection.

2 pump spas have a combined Up/Down key. Hold the button to increase the parameter and release the button to stop. Hold the button again to decrease the parameter.

The "Set Point" icon indicates that the display shows the desired temperature, NOT the current water temperature!

*If single speed pump: press Pump key to turn pump on. Press Pump key again to turn pump off.

USER INTERFACE - IN.K300

PROGRAMMING STEPS

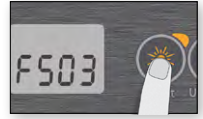

PROGRAM MENU



The program menu is accessible by holding down the Light key for 5 seconds. In the program menu the following parameters can be set: clock, the filter or purge cycles, economy mode and temperature units. While you are in the program menu, use the Up or Down key to adjust the parameters and use the Light key to jump to the next parameter.

The changes will be saved after the confirmation of the last parameter only. If there is no action taken for 10 seconds, the system will exit the program menu without saving any changes.

SETTING THE CLOCK

Enter the program menu by holding down the Light key for 5 seconds. The display will show the current clock setting with the hour flashing.

Depending on factory settings your system may be set to 24-hour time or 12-hour time.

Setting the hour: Use the Up or Down keys to adjust the hours. Press the Light key to jump to the next parameter, the minutes.

Setting the minutes: Use the Up or Down keys to adjust the minutes. Press the Light key to jump to the next parameter, the filter or purge start time (FS).

PROGRAMMING THE FILTER/PURGE CYCLES

Depending on system configuration your spa will perform either a filter or a purge cycle. The filter cycle menu consists of the following parameters: the start time (FS), the duration (Fd) and the frequency (FF). The purge cycle menu consists of the following parameters: the start time (FS) and the frequency (FF).

A filter cycle consists of starting all the pumps and blower in high speed for 1 minute (purge step) then, the pump associated with the filter will run in low speed for the remaining duration of the filter cycle (clean step).

A purge cycle is used when the spa is equipped with a 24 hour circulation pump which provides a continuous clean step. It consists of starting all the pumps and blower in high speed for 1 minute.

SETTING FILTER OR PURGE CYCLE START TIME

The display will show FSxx, "xx" representing the starting hour of the cycle. Use the Up or Down key to adjust the hours. Use the Light key to jump to the next parameter, filter duration (Fd).

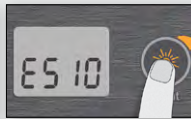
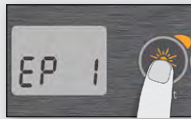
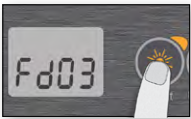

SETTING FILTER CYCLE DURATION

(not available on purge systems)

The display will show Fdxx, "xx" representing the duration in hours of the filter cycle. Use the Up or Down key to adjust the duration. Use the Light key to jump to the next parameter, filter or purge frequency (FF).

0 = no filtration

24 = continuous filtration

It is not recommended to set this to "0".

SETTING FILTER OR PURGE CYCLE FREQUENCY

The display will show FFxx, "xx" representing the number of cycles per day. Use the Up or Down key to adjust the frequency. Use the Light key to jump to the next parameter, economy mode (EP).

The "Filter cycle" indicator lights up when filter is on and flashes when suspended.

SETTING ECONOMY MODE

This mode allows you to lower the temperature set point of the spa by 20 °F (11 °C) during a certain period of the day.

The display will show EPx, "x" representing the state of the programmed economy (0 = disabled, 1 = enabled). Use the arrow keys to enable or disable economy mode. Use the Light key to jump to the next parameter, economy start time (ES).

SETTING ECONOMY START TIME

The display will show ESxx, "xx" representing the hour at which the economy mode will become active. Use the Up or Down key to adjust the hour. Use the Light key to jump to the next parameter, economy duration (Ed).

When the Economy mode is ON, the display will toggle between the "Eco" message, the time, and the water temperature.

SETTING ECONOMY DURATION

The display will show Edxx, "xx" representing the duration in hour of the economy mode. Use the Up or Down key to adjust the hour. Use the Light key to jump to the next parameter, temperature unit.

24 = continuous economy

Note that the parameters for the economy mode settings are associated to specific low level configuration of the system that are not present in all software revisions.

USER INTERFACE - IN.K300



SETTING TEMPERATURE UNIT

Water temperature can be displayed in either Fahrenheit (°F) or Celsius (°C). The display will show F or C.

Use the Up or Down key to change the setting. Use the Light key to save all the parameters.

SMART WINTER MODE

Our Smart Winter Mode protects your system from the cold by turning pumps on several times a day to prevent water from freezing in pipes.

The "SWM" indicator lights up when freezing is detected and flashes when the purge is active.

COOLDOWN

After heating the spa water to the desired Set Point, the heater is turned off, but its associated pump (Pump 1 low-speed or CP) remains on for a predetermined period of time to ensure adequate cooling of the heating element, prolonging its useful life.

WATER TEMPERATURE REGULATION

Every 15 to 90 minutes the pump will run to ensure accurate water temperature readings as well as avoid heater activation in dry conditions. After verifying pump activation and taking a water temperature reading if required, the system

automatically turns the heater on to reach and maintain water temperature at Set Point.

 Indicator flashes when taking water temperature reading.

TROUBLESHOOTING SECTION

Should an error occur, the display will show one of the following error messages toggled with the clock and the water temperature.

IN.XE ERROR CODES

DESCRIPTION



Hr
An internal hardware error has been detected in the in.xe.
Contact dealer or service supplier.



HL
The system has shut the heater down because the temperature at the heater has reached 119°F (48°C).
Do not enter the water! Remove the spa cover and allow the water to cool down, then shut power off and power your spa up again to reset the system.



AOH
Temperature inside the spa skirt is too high, causing the internal temperature in the in.xe to increase above normal limits. Open skirt and wait until error clears.



FLO
The system does not detect any water flow while the primary pump is running.
Check and open water valves. Check for water level.
Clean filter. If the problem persists, call your dealer or service supplier.



Prr
A problem is detected with the temperature probe.
Call your dealer or service supplier.



OH
The water temperature in the spa has reached 108°F (42°C).
Do not enter the water! Remove the spa cover and allow the water to cool down to a lower temperature.
Call your dealer or service supplier if problem persists.

OTHER ACCESSORIES - THE HEAT PUMP (OPTIONAL)

For further information see the original user manual of the heatpump. It shows the installation and technical details.

CONTROL PANEL

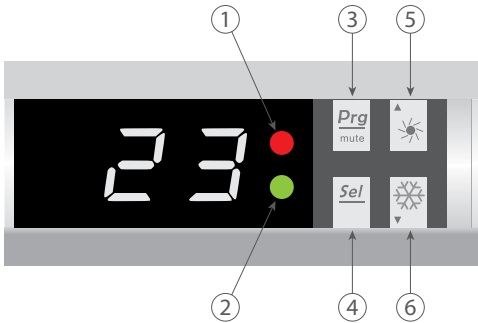

1. Heating mode indicator
2. Cooling/Defrost mode indicator
3. ON/OFF button
4. Mode button
5. Plus (+) button
6. Minus (-) button

OPERATING MODE SELECTOR



BEFORE STARTING, ENSURE THAT THE FILTRATION PUMP IS WORKING AND THAT WATER IS CIRCULATING THROUGH THE HEAT PUMP.

Prior to setting your required temperature, you must first select an operating mode for your remote control:



HEATING MODE

Select the heating mode for the heat pump to heat the water in your spa.





COOLING MODE

Select the cooling mode for the heat pump to cool the water in your spa.

OTHER ACCESSORIES - THE HEAT PUMP (OPTIONAL)

HEATING MODE

Step 1: Press  to switch on your pump.

Step 2: Press  to switch from one mode to another until the heating mode is displayed.

Step 3: Using buttons  and  select the required temperature.

EXAMPLE:

If the current temperature is 15°C, default setting temperature is 27° required temperature is 30°C.

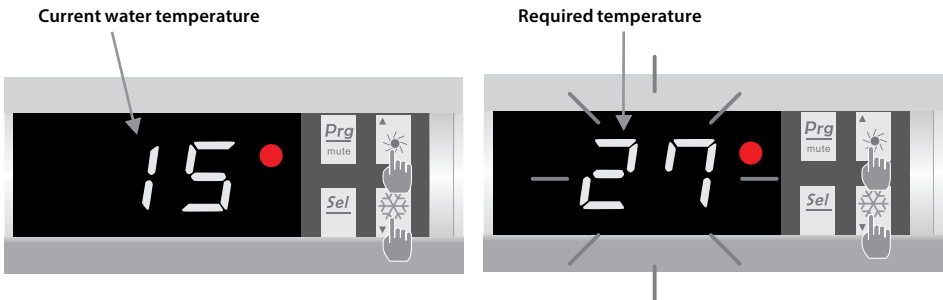

USEFUL INFORMATION ABOUT HOW THE HEATING MODE OPERATES

When the incoming water temperature is less than or equal to the required temperature (setpoint temperature) -X°C, the heat pump will switch to heating mode. The compressor will stop when the temperature of the incoming water is greater than or equal to the required temperature (setpoint temperature).

Indicators for adjustment range X and Y

X: adjustable parameter from 1° to 10°C, default setting is 3°C. (Parameter "H")

OTHER ACCESSORIES - THE HEAT PUMP (OPTIONAL)

COOLING MODE

Step 1: Press  to switch on your pump.

Step 2: Press  to switch from one mode to another until the cooling mode is displayed.

Step 3: Using buttons  and  select the required temperature.

EXAMPLE:

If the current temperature is 30°C, default setting temperature is 27° required temperature is 15°C.

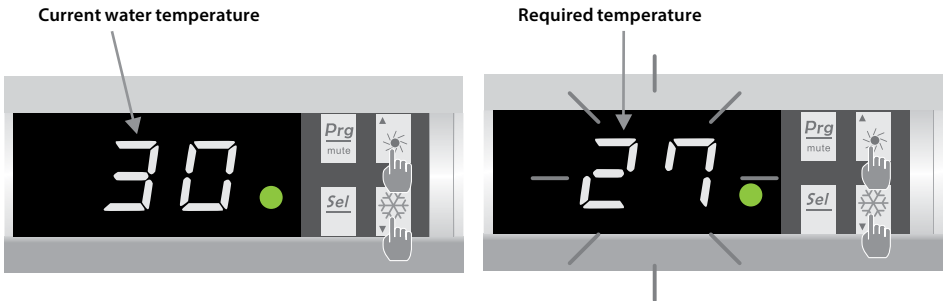

USEFUL INFORMATION ABOUT HOW THE COOLING MODE OPERATES

When the incoming water temperature is greater than or equal to the required temperature (setpoint temperature) + X°C, the compressor will switch to cooling mode. The compressor will stop when the temperature of the incoming water is less than or equal to the required temperature (setpoint temperature).

Indicators for adjustment range X

X: adjustable parameter from 1° to 10°C, default setting is 3°C. (Parameter "H")

OTHER ACCESSORIES - THE HEAT PUMP (OPTIONAL)

STATUS VALUES AND ADVANCED SETTINGS



WARNING: This operation is used to assist servicing and future repairs.
The default settings should only be modified by an experienced professional person.

THE SYSTEM'S SETTINGS CAN BE CHECKED AND ADJUSTED VIA THE REMOTE CONTROL BY FOLLOWING THESE

Step 1: Keep pressing  until you enter the settings verification mode.

Step 2: Press  and  for see the parameters.

Step 3: Press  to select the setting to be modified.

Note, some settings cannot be modified. Consult the settings table for further information.

Step 4: Press  and  to adjust the setting value.

Step 5: Press  to set the new value.

Step 6: Press  to return to the main screen.



PARAMETERS TABLE

N°	Description	Range value	Default value	Comment
A	Water temperature	-19~99°C		Actual data
b	Evaporator temperature	-19~99°C		Actual data
c	Ambient air temperature	-19~99°C		Actual data
d	Setting temperature in heating mode	15~40°C	27°C	Adjustable
E	Defrosting mode activation timer	10~80 min	40 min	Adjustable
F	Defrosting mode maximum duration	5~30 min	8 min	Adjustable
G	Setting temperature in cooling mode	8~28°C	12°C	Adjustable
H	Adjustment of temperature difference for restart	1~10°C	3°C	Adjustable
J	Automatic restart	0=OFF, 1=ON	1	Adjustable
O	Antifreeze protection – low air temperature	-10~15°C	-5°C	Adjustable
P	Evaporator temperature to enter defrosting mode	-19~0°C	-3°C	Adjustable
U	Evaporator temperature to exit defrosting mode	1~30°C	20°C	Adjustable
t	Reserved - Do not modify			Reserved
L	In.grid	0=OFF, 1=ON	1	Adjustable

For further information see the original user manual of the heatpump. It shows the installation and technical details.

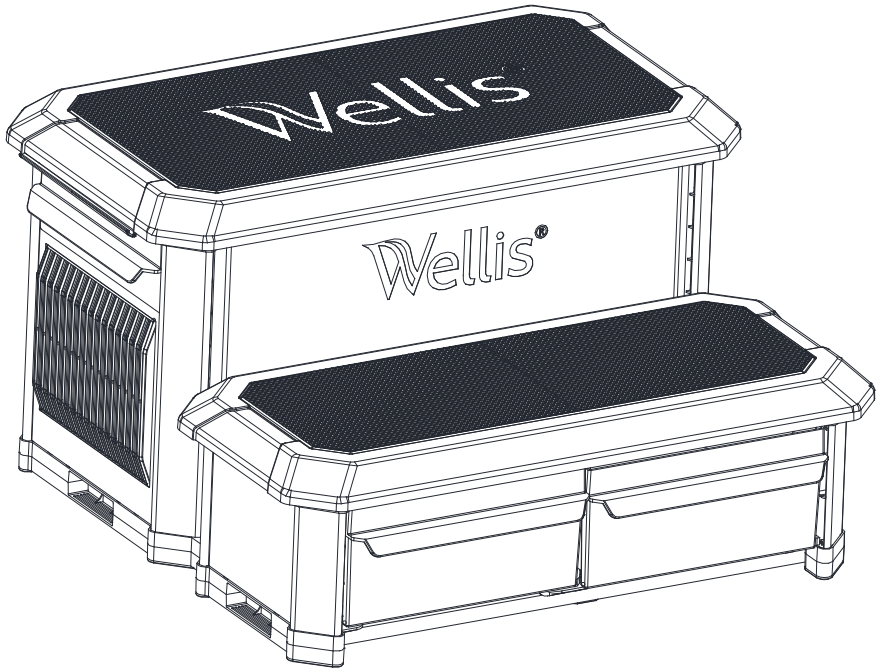

SMART STEP MANUAL (OPTIONAL)

SAFE USE

To reduce the risk of drowning, falls, paralysis, electrocution, or other serious injury or death:

Use step properly.

Use for intended purpose only.

- **No diving or jumping from steps** - shallow water, risk of paralysis or death.
- **ONE PERSON ON THE LADDER/STAIR AT A TIME.**
- **Illuminate the steps** when using the spa at night.

Weight limit - 300 lbs maximum. Exceeding maximum weight may cause the step to fail.

Secure the spa when not in use. - (for example, with a locked cover or secure gate) - refer to local codes.

Watch children at all times when they are in or around water to help prevent drowning.

BE SURE AND SAFE. - The manufacturer **IS NOT** responsible for improper assembly, installation and use.

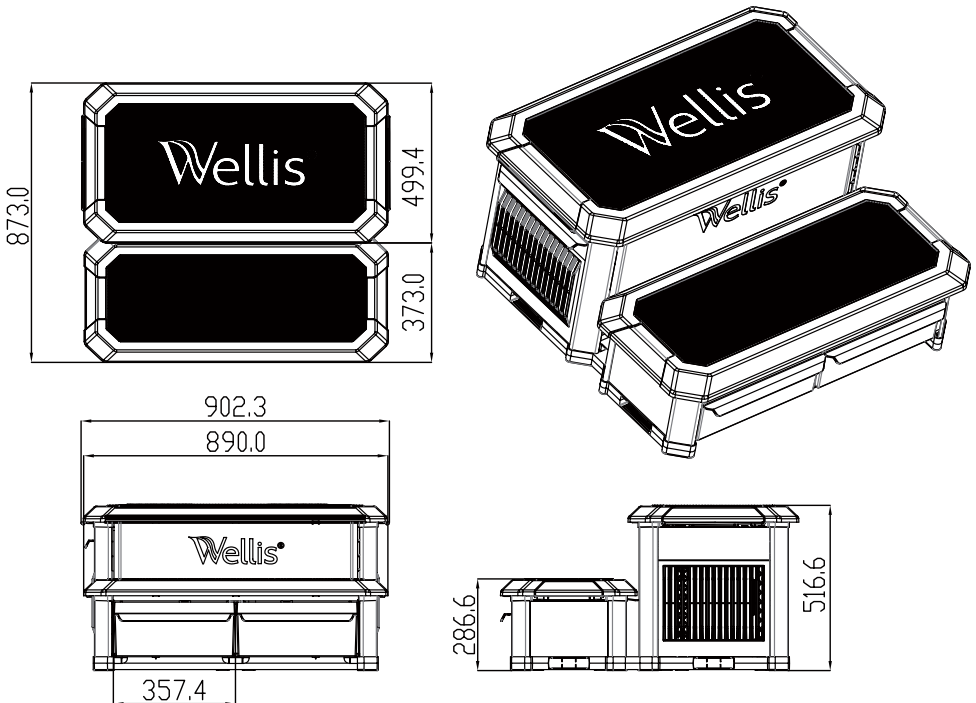

SMART STEP MANUAL (OPTIONAL)

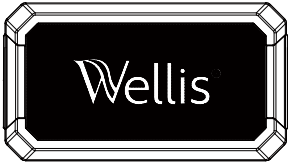

WE0135-1

1x

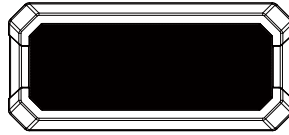

WE0135-2

1x

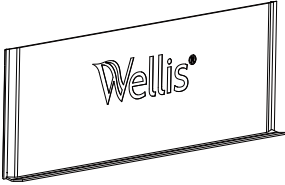

WE0135-5

1x

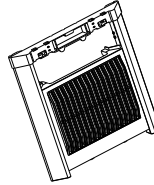

WE0135-6

1x

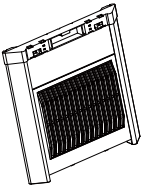

WE0135-7

1x

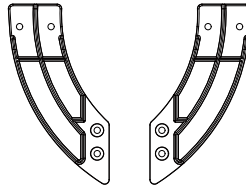

WE0135-10&11

1x

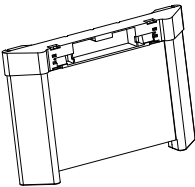

WE0135-13

2x

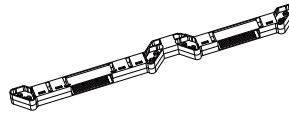

WE0135-14

2x

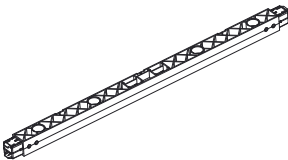

WE0135-15

11x

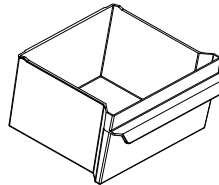

WE0135-16

2x

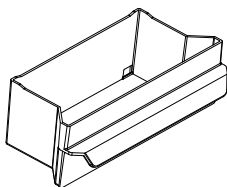

WE0135-17

1x

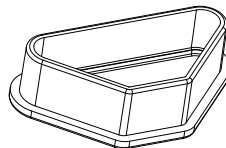

WE0135-18

8x

SMART STEP MANUAL (OPTIONAL)

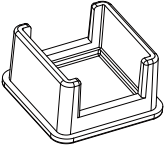

WE0135-19

5x

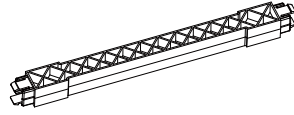

WE0135-20

2x

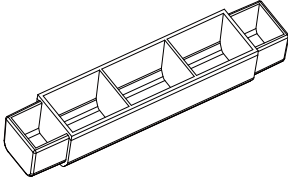

WE0135-21

2x

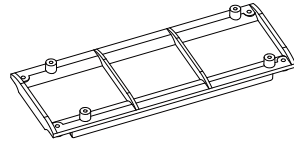

WE0135-22

2x

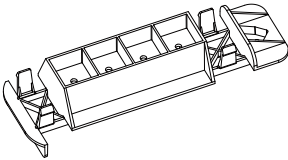

WE0135-23

2x

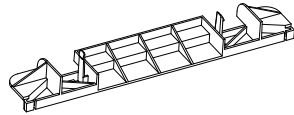

WE0135-24

2x

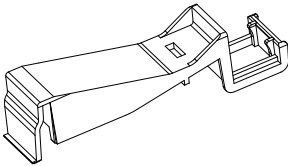

WE0135-25

6x

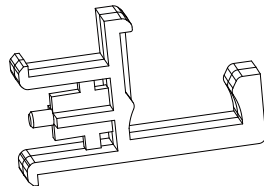

WE0135-26

8x

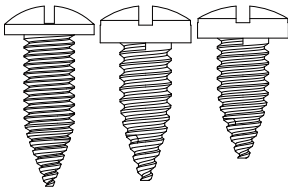

M4.2X14

16x

M3X14

4x

M3X10

16x

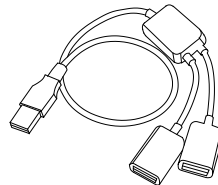

USB

1x

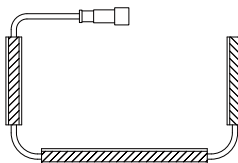

LED lights
Three paragraphs

1x

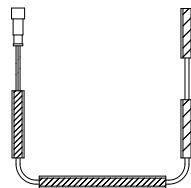

LED lights
Four paragraphs

1x

SMART STEP MANUAL (OPTIONAL)

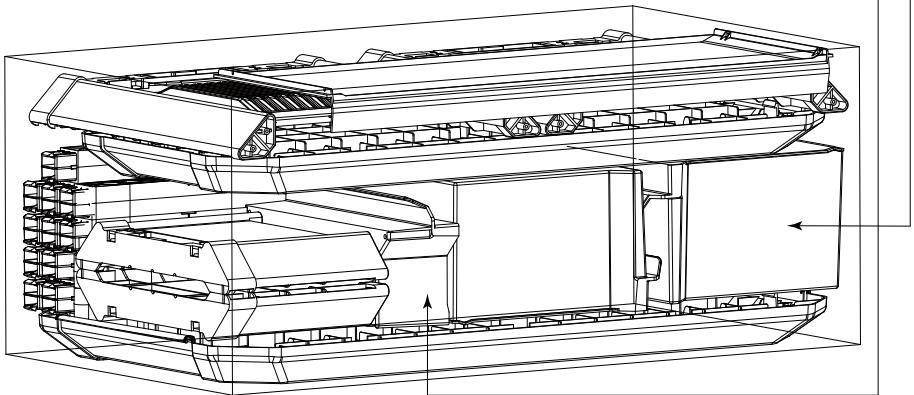
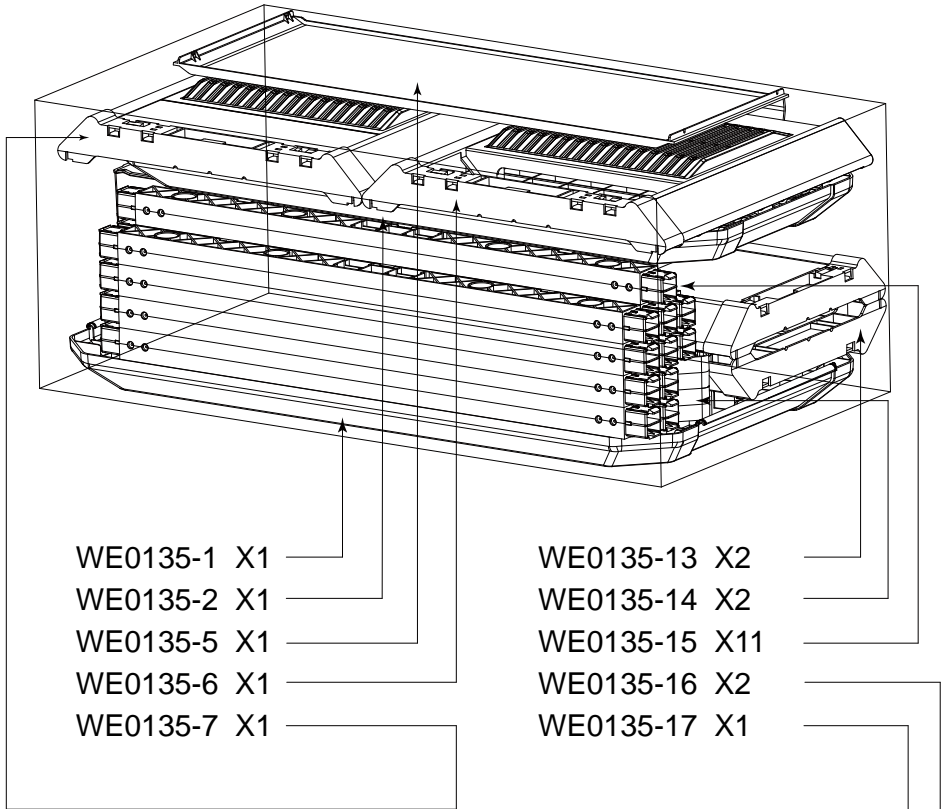

SMART STEP MANUAL (OPTIONAL)

1

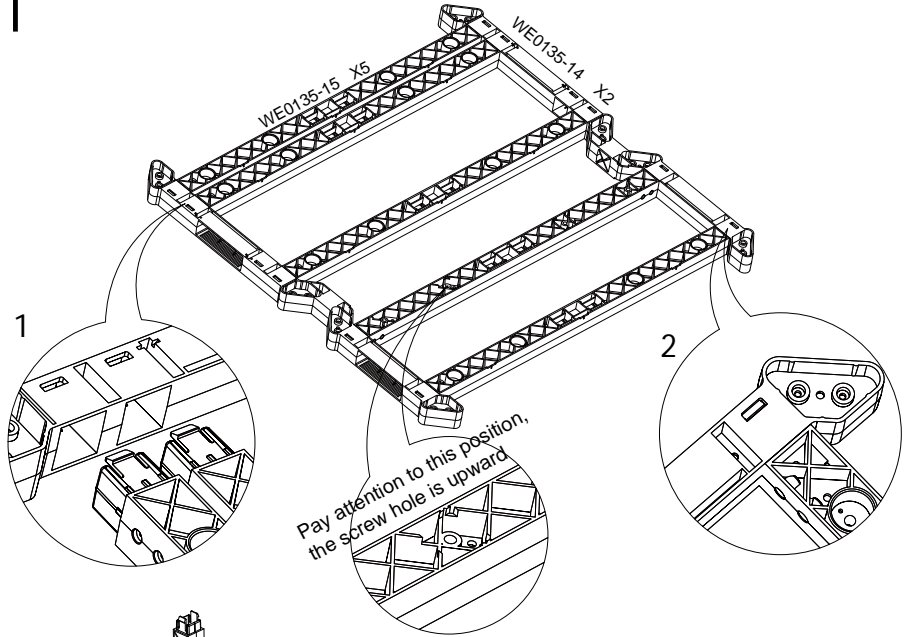

2

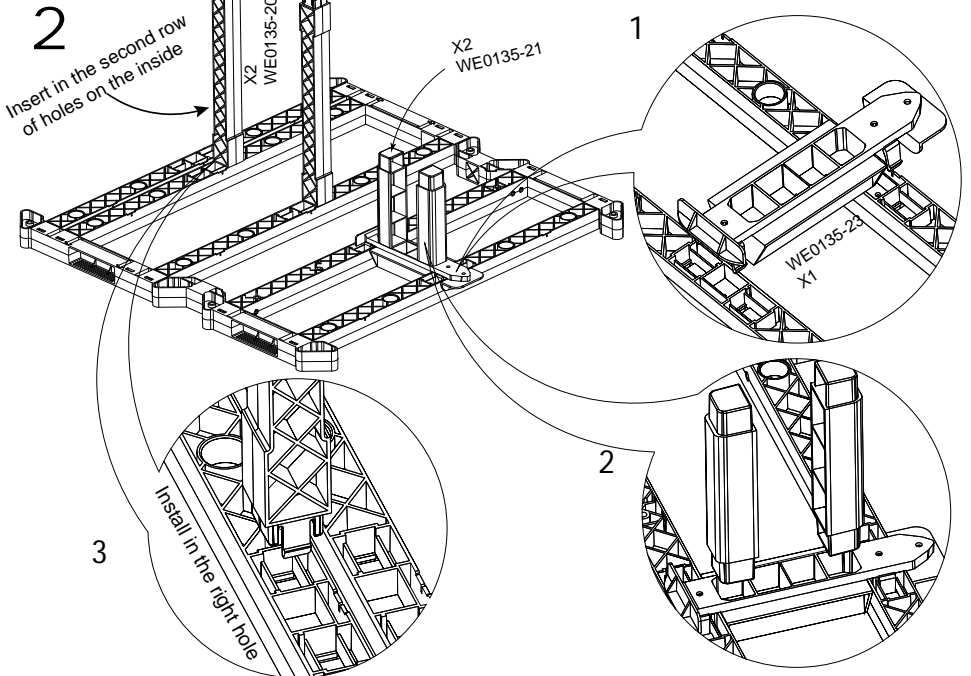

3

Install in the right hole

3

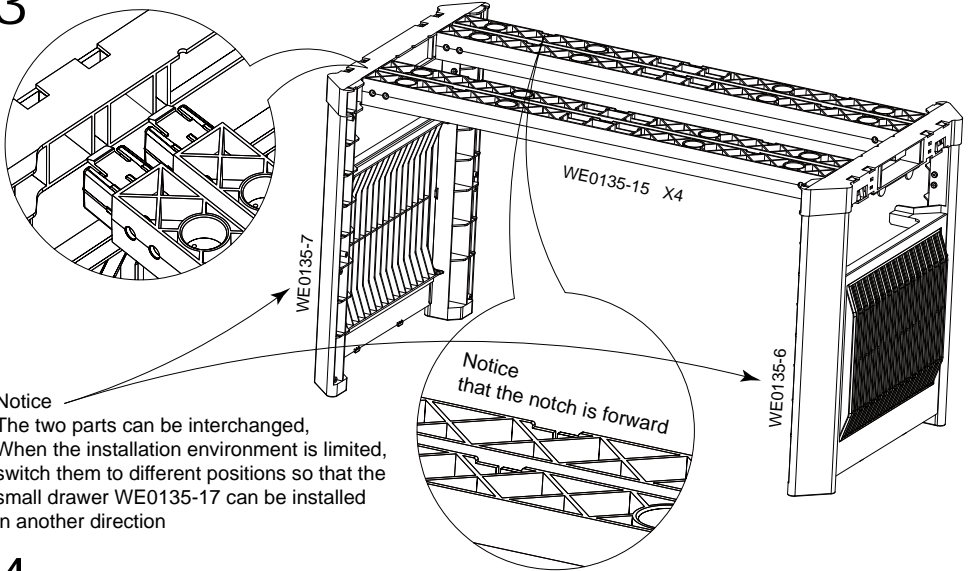

Notice
 The two parts can be interchanged,
 When the installation environment is limited,
 switch them to different positions so that the
 small drawer WE0135-17 can be installed
 in another direction

4

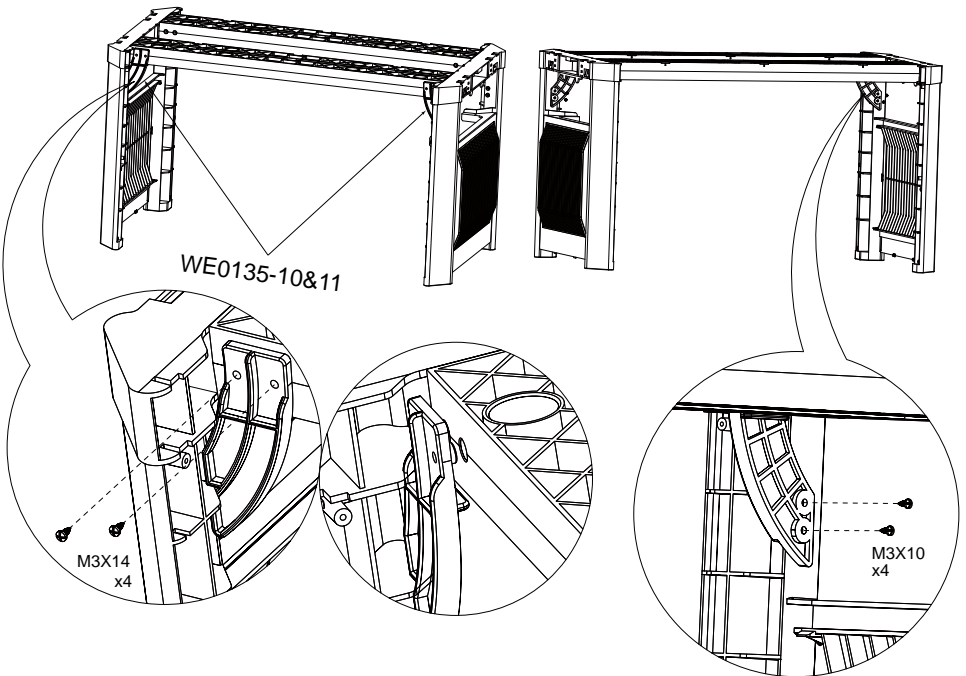

5

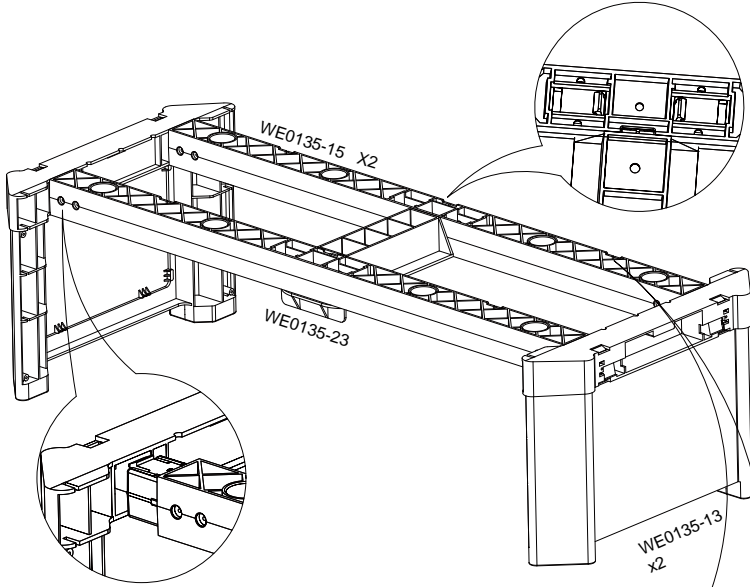

6

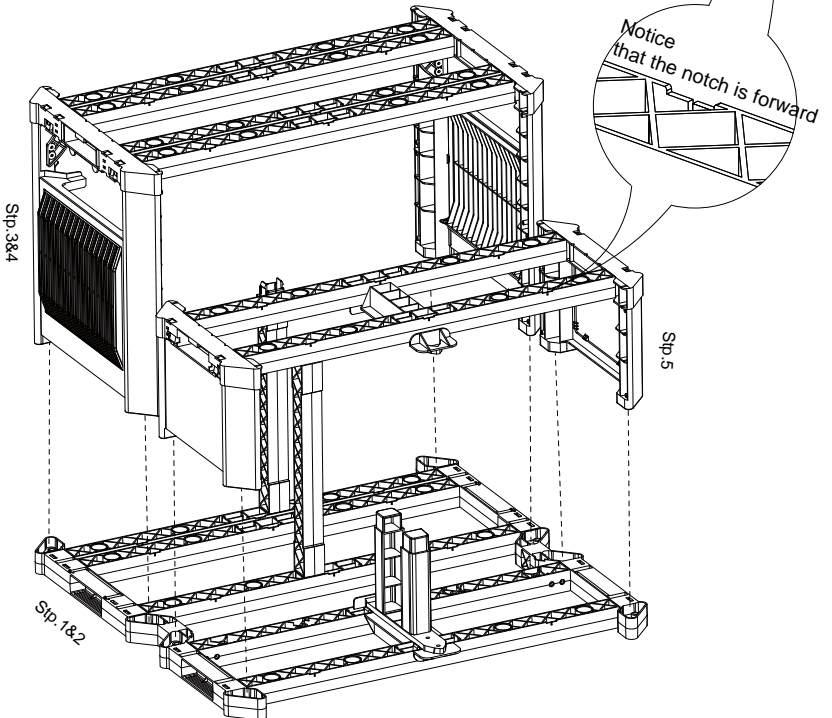

SMART STEP MANUAL (OPTIONAL)

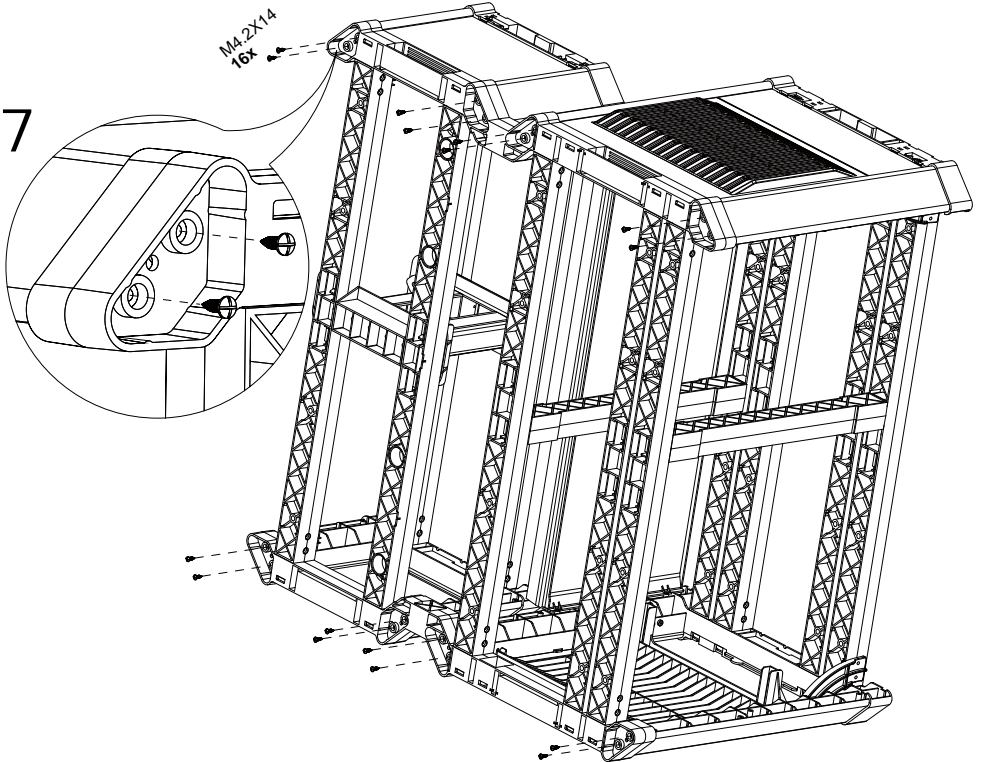
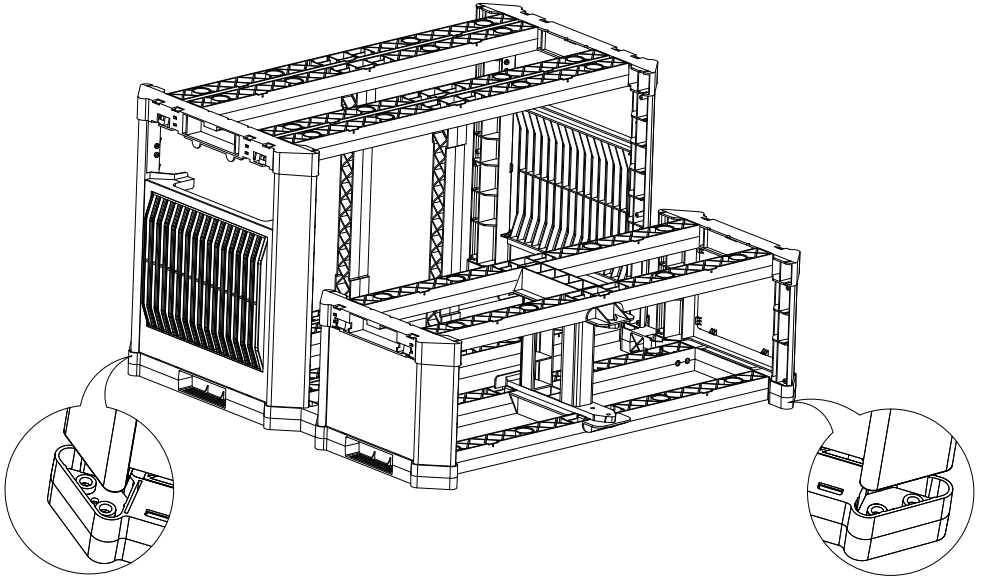

SMART STEP MANUAL (OPTIONAL)

8

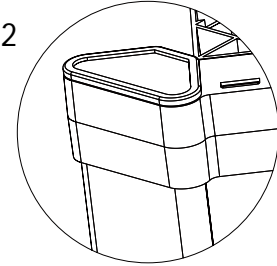
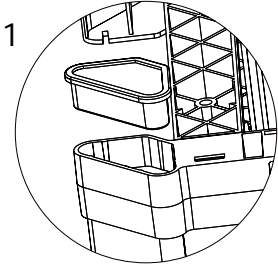
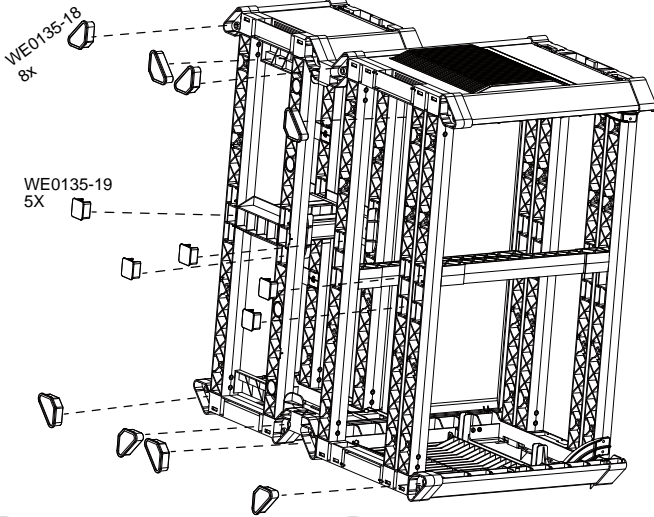

9

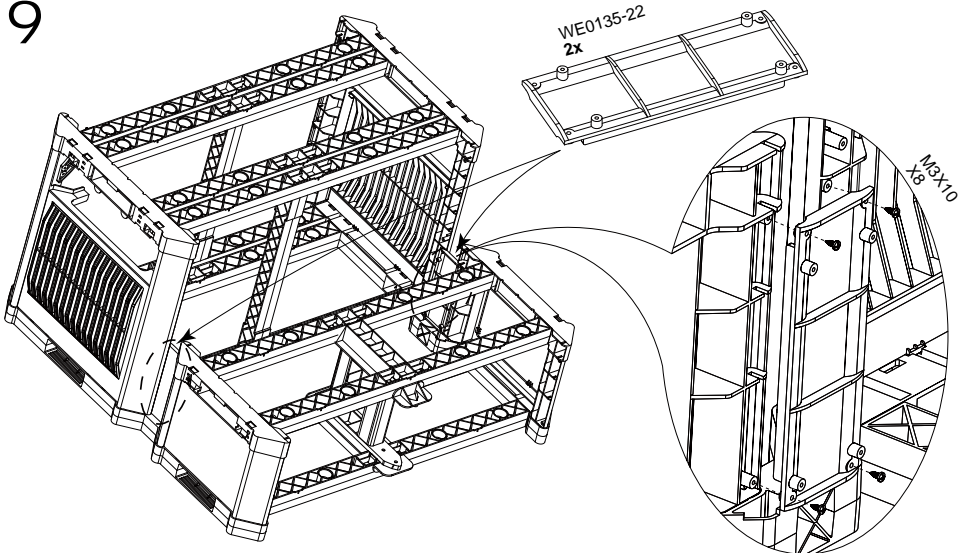

10

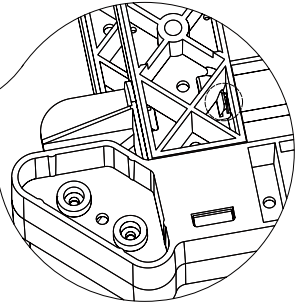
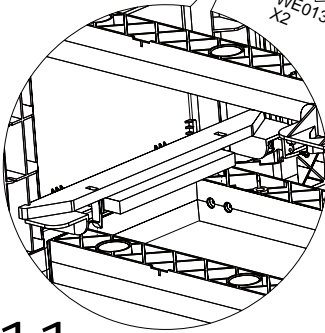
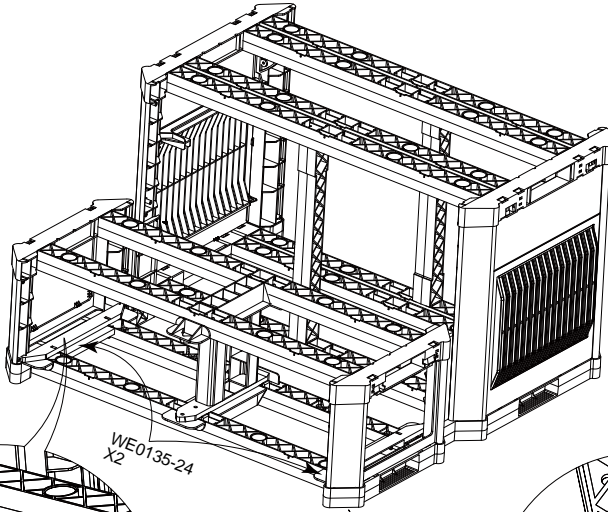

11

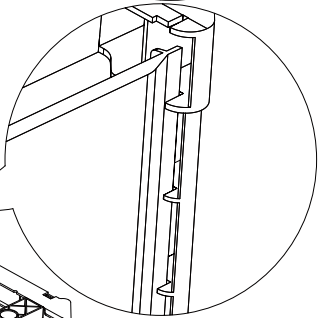
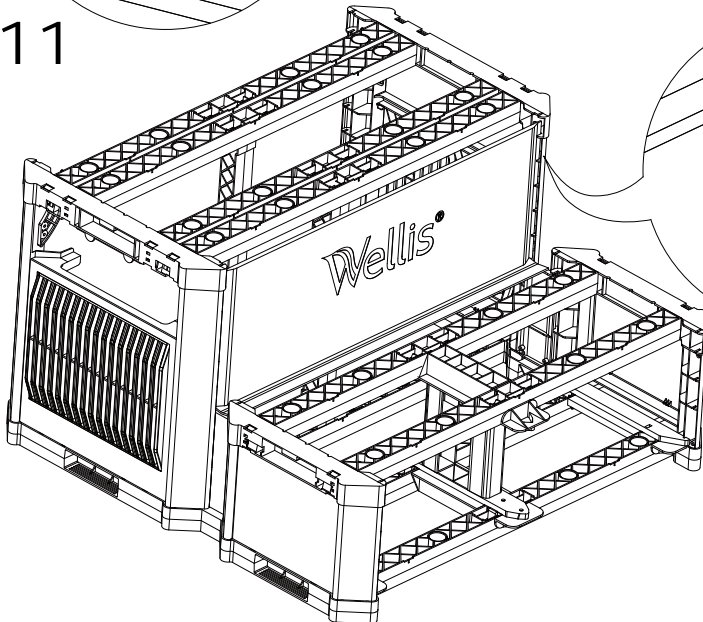

SMART STEP MANUAL (OPTIONAL)

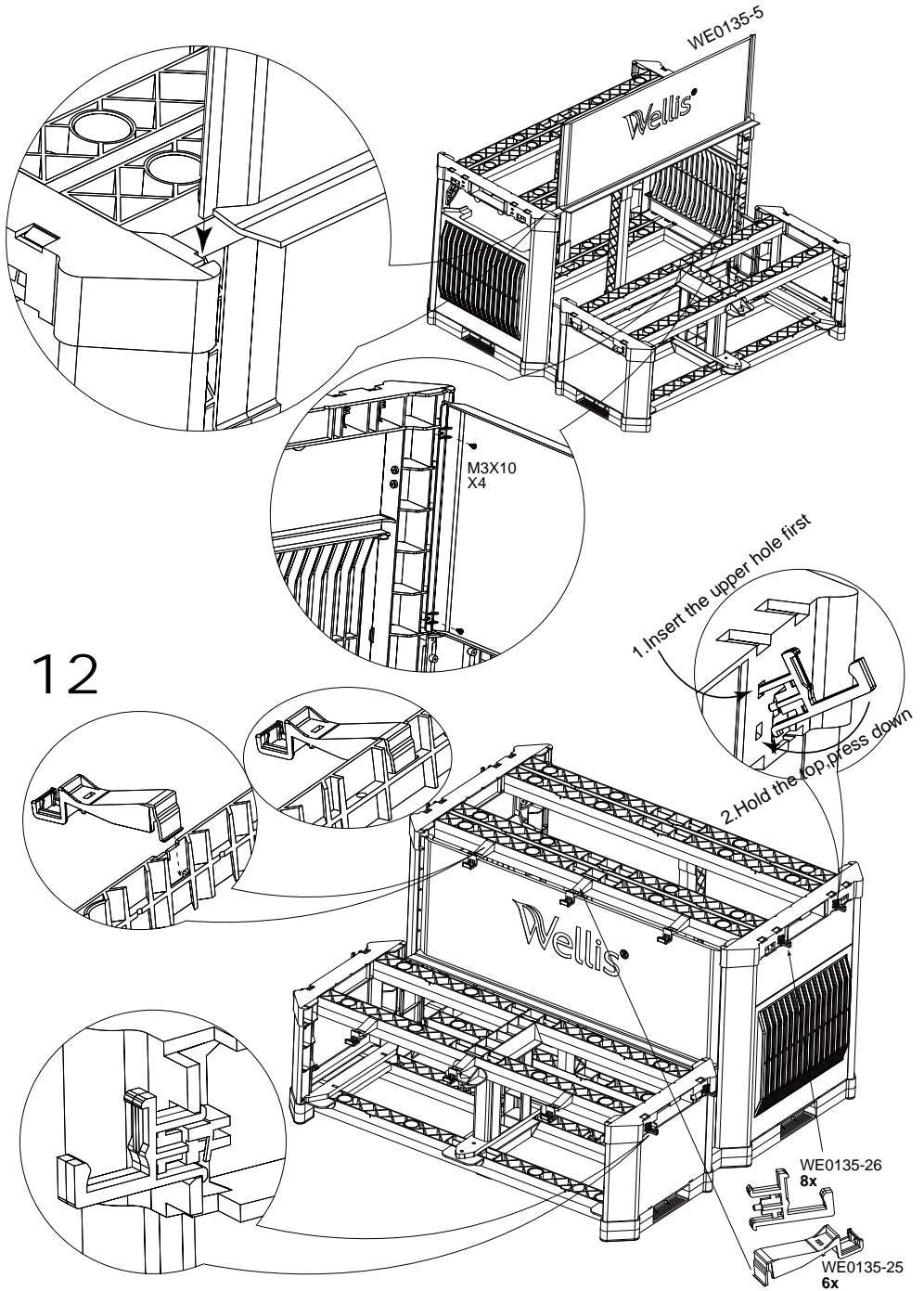

13

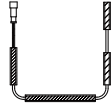

LED lights
Four paragraphs
1x

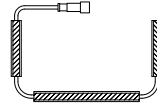

LED lights
Three paragraphs
1x

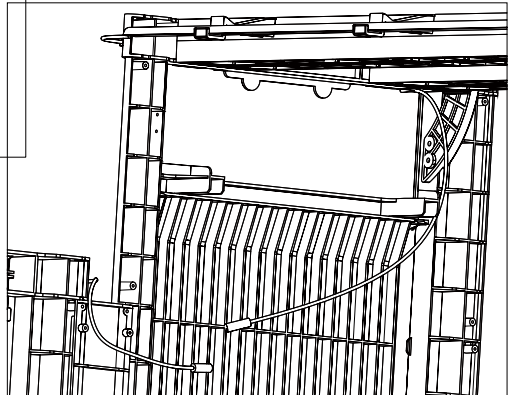
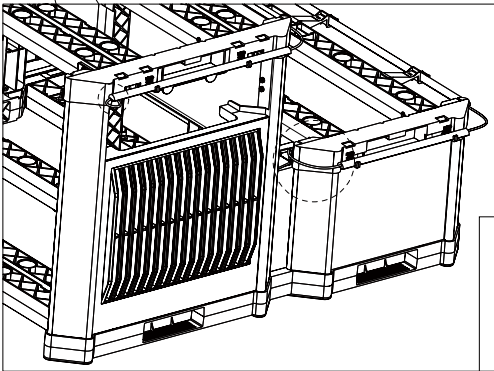
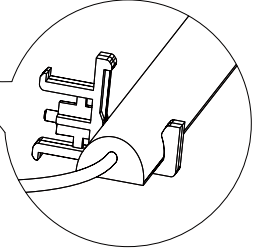
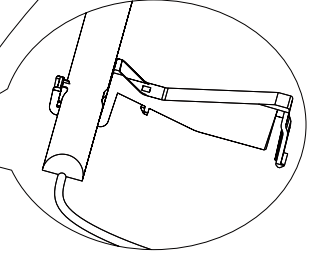
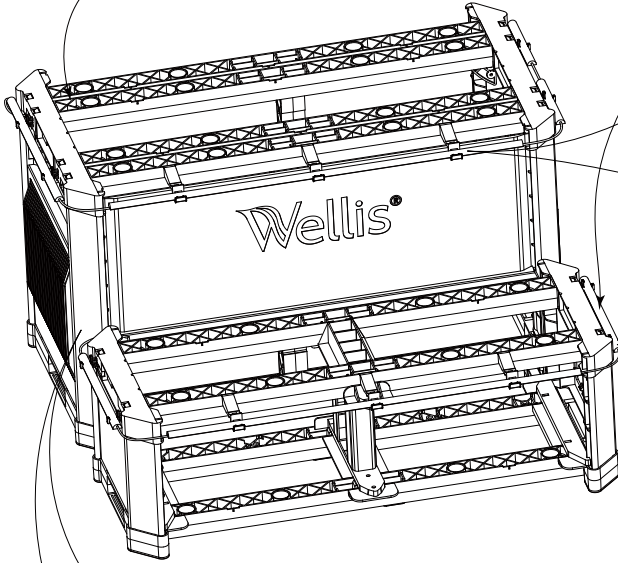

14

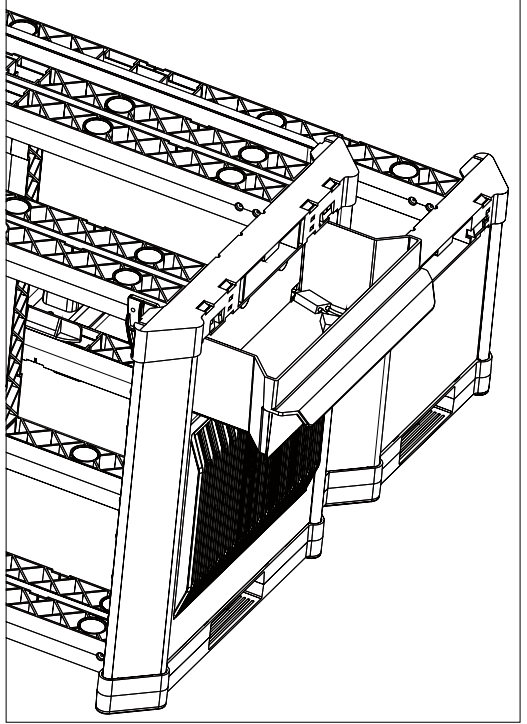
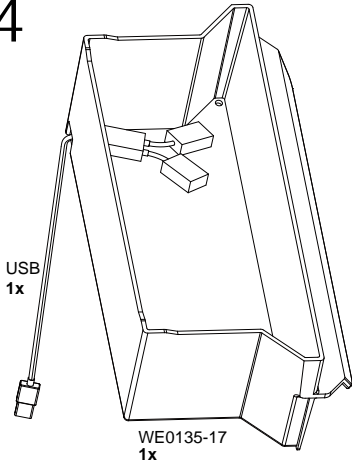

15

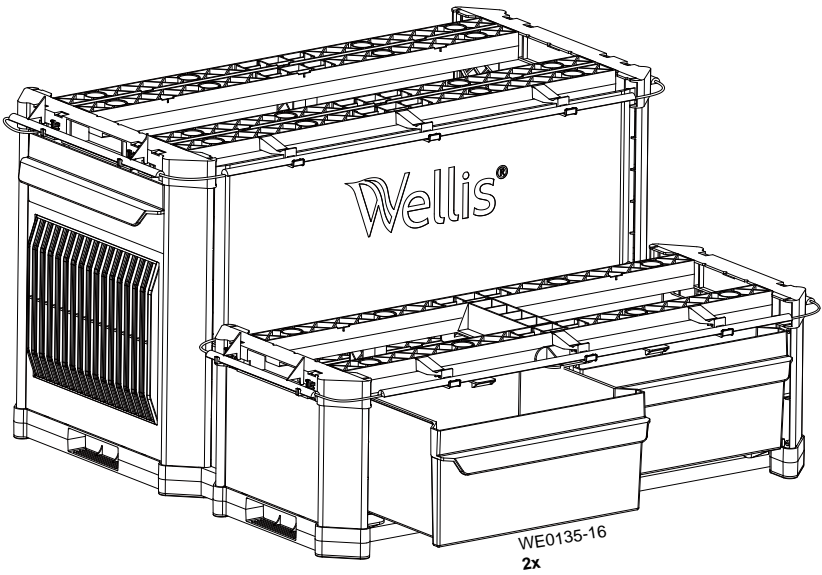

16

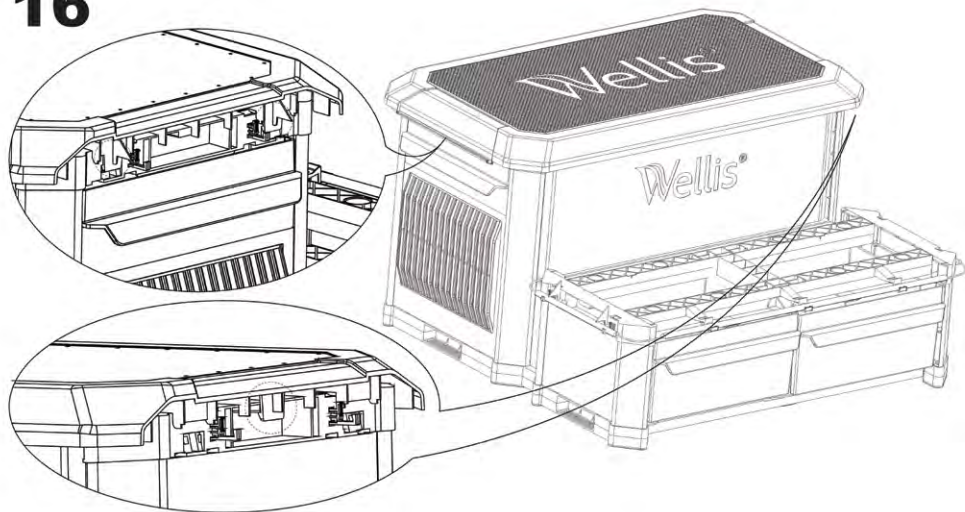

17

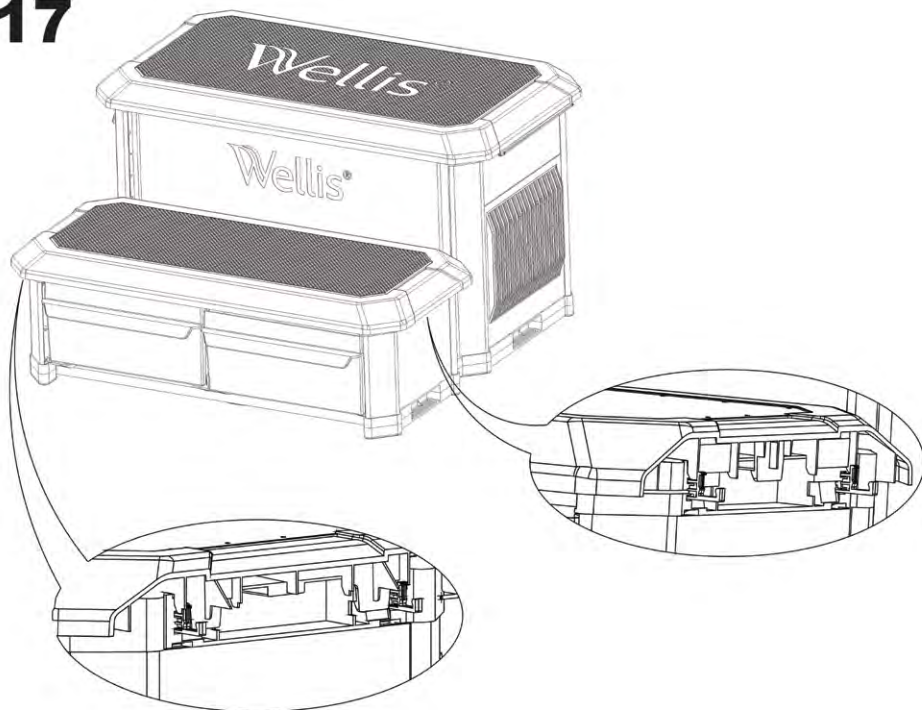

OTHER ACCESSORIES - IN.GRID

Heat Mode Operations

You can choose between four different water regulation modes available. Your in.grid is automatically detected by the spa control system at power up. It will be ready to use with your preferred heat mode one minute following power up.

The relay contacts of the in.grid will be closed if the external heating system is activated. Otherwise, the relay contacts are open.

Your desired heat mode must be set by adding a jumper on one of the five (5) different positions.

***Note:** Your heat mode selection can be changed with the in.touch 2 app on your mobile device. On your app, any new selection will override the jumper setting of the in.grid. The in.touch 2 app will automatically detect the in.grid presence and will adapt its menu configuration as required.

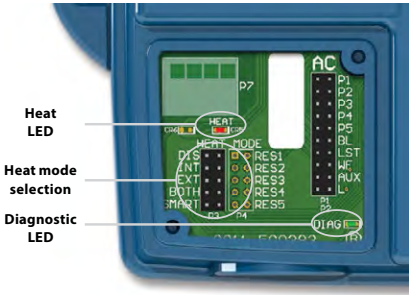

Use this mode for a maximum energy saving purpose. The spa control system will only use your external heating system to regulate the water temperature. In normal operation, the internal heater will never be activated.

Freeze Protection

Freeze protection has been added because EXT (EXTERNAL) mode does not allow the activation of the internal heater. In cold weather, if it becomes impossible to keep the water over freezing point, the help of the internal heater will then be needed. This is the only time the freeze protection will come in.

At any time, if the water temperature drops to 40°F (4.5°C), the resistive heater will give a boost to avoid freezing. The freeze protection will stay active until water temperature reaches the minimum allowed set point (usually 59°F / 15°C). Normal EXT mode will resume functioning thereafter.

4- BOTH (BOTH SYSTEMS ALL AT ONCE)

The spa control system will always use the external heating system AND the internal heater simultaneously to regulate the water temperature; they are both activated or deactivated at the same time.

5- SMART (ENERGY SAVINGS)

The spa control system will always use the external heating system to regulate the water temperature. If the temperature falls too far below your set point (-2.5°F), the internal heater will be activated to help your external heating system reach the set point.

Five available heat modes are offered with in.grid:

1- DIS (DISABLED)

Use this mode if the spa configuration does not have any external heating system and only the single switch functionalities are used. This will avoid in.touch 2 application on a mobile device to display the Heat Mode Selection menu*. The spa controller will regulate the water temperature using the standard resistive heater. The single button switches will control the different spa accessories according to the AC jumper selections.

IMPORTANT: This mode can only be set with the heat mode jumpers.

2- INT (INTERNAL)

This mode provides an easy way to revert back to standard water regulation using the internal heater in case of problem with the external heating system.

3- EXT (EXTERNAL)

Troubleshooting

DIAGNOSTIC LED

The diagnostic LED will help you with the status of the connection between the spa control system and the in.grid.

Blinking light: Spa control system not detected, not compatible or in Disable mode if one of your single switches doesn't operate properly.

Solid light: Spa control system detected

No light: Power Off

HEAT LED

Solid light: Relay contacts close and external heating system on.

No light: Relay contacts open and external heating system off.



in.touch 2

Easily integrate your spa to the Internet of Things!

Simplest of setups

in.touch 2 eliminates all the complexities of connecting your spa to the Internet and transforms your smartphone or tablet into your ultimate Wi-Fi spa remote control. in.touch 2 comes with a state-of-the-art app and 2 prepared radio frequency transmitters, one being part of your spa system and the second one being connected to your Internet router. Both RF transmitters are prelinked to one another, enabling an immediate and perfect communication between you and your spa.

Strong and long range communication signal

Through their proprietary RF technology, in.touch 2 transceivers emit a strong, stable and long range signal between your spa and your router (about 3 times longer than regular Wi-Fi signal). No need for repeaters or boosters: your spa will always remain within reach in typical backyard settings.

State-of-the-art app with push notifications

in.touch 2 streamlined application makes it very easy to control and program all the functions and features of your spa from your smartphone or your tablet. Even when you're away from home, you get full control of your water care settings, filtration cycles, water temperature, economy modes and a lot more. Push notifications will always keep you informed on the status of your spa, even when your app is not open.

in.touch 2 overview

Home Transmitter (EN Module)

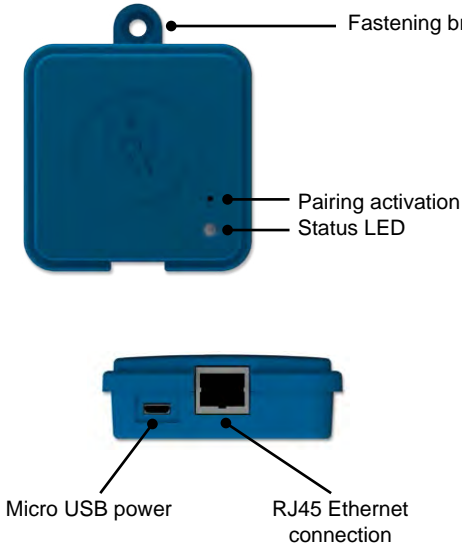

Spa Transmitter (CO Module)

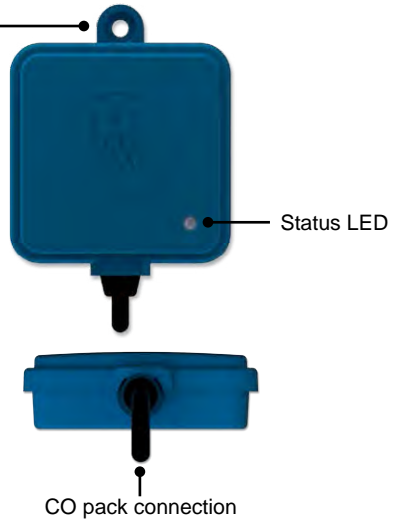

in.touch 2 dimensions

Home Transmitter (EN Module)

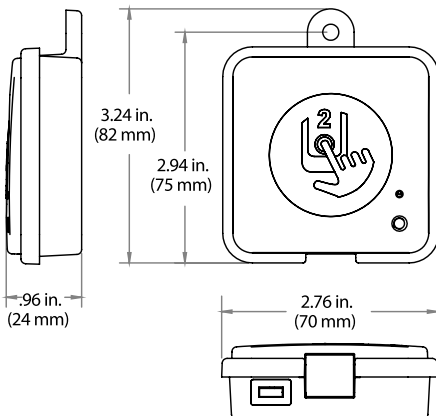

Spa Transmitter (CO Module)

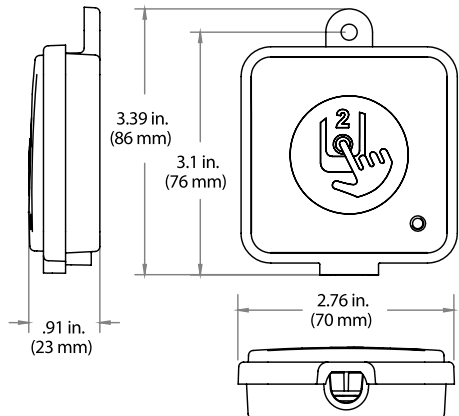

Home Transmitter (EN Module) installation

The Home Transmitter unit must be installed inside the house near the router as it needs to be connected to it. The Home Transmitter is provided with an Ethernet cable and a power supply. If required, a longer cable of good quality can be used by the installer (longer cable not provided) to install the Home Transmitter closer to the spa within the home.

The only requirement for installation location is that household current be available to power the Home Transmitter using the provided wall transformer.

The Home Transmitter can be fixed in the house to optimize the signal strength. We recommend that you install the unit with a #8 pan head screw.

Here are some suggestions for a successful installation:

- If possible, install device on the first floor of your house.
- If installing in a basement, place at highest level possible and closest to a window.
- Try to install as far as possible from materials that may interfere with signal (ie. metal structures, thick cement walls).
- Install as far as possible from router as the signal emitted by the antenna may interfere with RF signal.

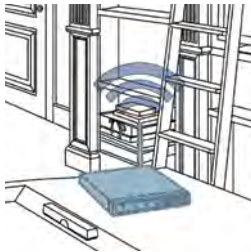

Connection of the Home Transmitter (EN Module)

Simply connect Ethernet cable into the RJ45 port of the Home Transmitter and in one of the available LAN ports on the router.

Finally, to power up the Home Transmitter, connect the provided transformer to a 120V (North American model) or 220V (European model) household supply and connect the USB cable between the transformer and the Home Transmitter.

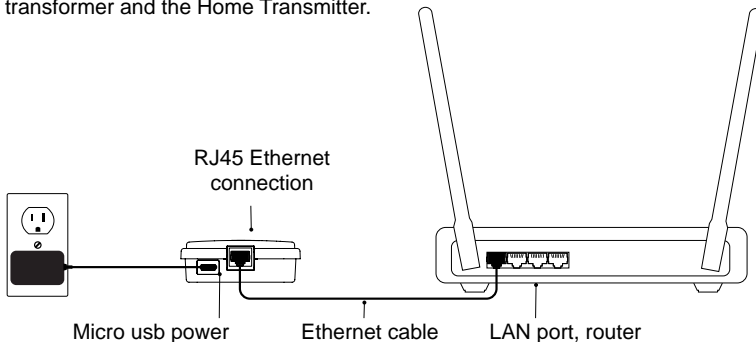

Pairing the Spa Transmitter (CO Module) and the Home Transmitter (EN Module)

The pairing process is used when you need to replace one module of the in.touch 2 kit. Otherwise, the in.touch 2 arrives pre-paired from the factory.

1. Power up the Home Transmitter

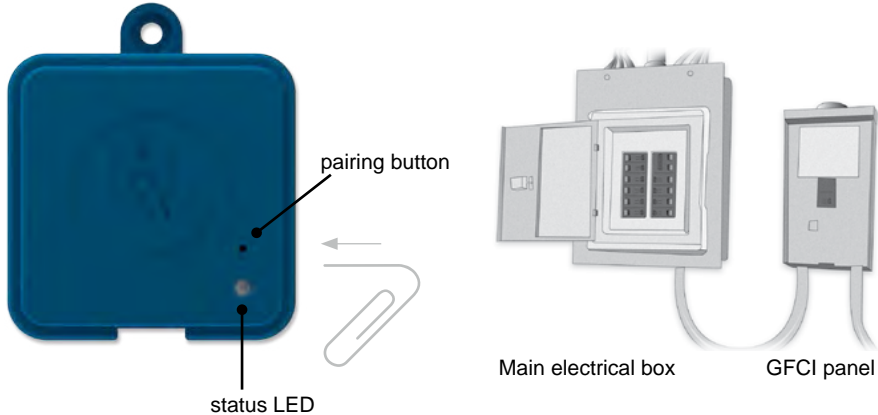

- Press on the pairing button with a paper clip or some similar tool. When the pairing mode is active the status LED flashes YELLOW in a rapid pattern. The Home Transmitter is then in pairing mode and will remain in this mode until it pairs with an Spa Transmitter, or until it is reset (power cycled).
- Shut off the spa's breaker (thus turning off the Spa Transmitter), wait a few seconds, and then flip the breaker back on. Within a few seconds, the pairing operation should complete and the Home Transmitter status LED will no longer be YELLOW.

Note: in.touch 2 modules can be paired as often as necessary, but can only be paired with a single counterpart module at a time. Once paired, the modules store this information permanently until the next pairing operation. Pairing information is stored in non-volatile memory, so pairing is not required after a power failure. Only a Home Transmitter can initiate a pairing, so it is important that the pairing begin with putting the Home transmitter module in pairing mode.

If several spas are powered up at the same time with a Home Transmitter in pairing mode (for instance, in a dealer showroom), only the 1st spa to successfully connect to the Home Module will pair. As this can be random, it is recommended that only 1 spa be powered up at a time during the pairing process.

LED

Each in.touch 2 module has a status LED that can be used for troubleshooting purposes. The LED is located on the top of both enclosures.

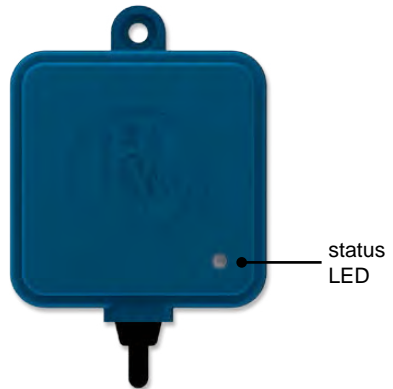
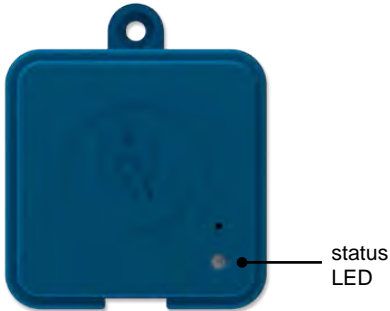

Home Transmitter

Pairing mode Yellow (Blinking)	●
Router not detected	●
Router detected	●
in.touch 2 server detected	●
Module is fully functional	●

Spa Transmitter

Pairing mode Yellow (Blinking)	●
Spa controller not detected	●
in.touch 2 server detected	●
Module is fully functional	●

** When the LED status is blinking (blue, green or red) this indicates that the communication between the EN module and the CO module is not established.*

Download application



The in.touch app allows you to control your spa using your home network or an Internet connection anywhere in the world. The Wellis Spa Control (in.touch 2) app is waiting for you in the App Store for iOS devices and on Google Play for Android — search for «Wellis Spa Control» then click on it to install.

Use this application

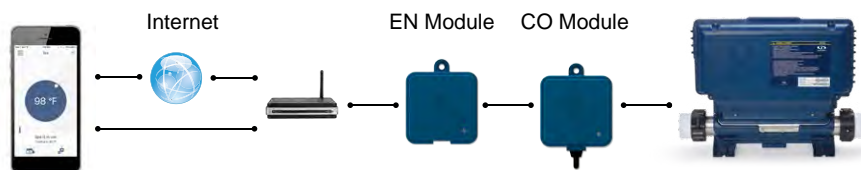

On your home network

It is possible to access your spa with the in.touch 2 app through your home network. To be able to see your in.touch 2 in the application you need to connect your device to the same router (Wi-Fi network) than the one used to connect your Home Transmitter

Go to the Wi-Fi settings section of your mobile device and choose the same network that your spa is connected to (i.e. Home). Once you've selected it, wait until your device confirms the connection.

On the Internet

The in.touch 2 allows you to use the Internet to control your spa from anywhere in the world. In order for them to communicate, both the in.touch 2 module and your device must be connected to a network that allows access to the Internet.

Once your Home Transmitter is connected to the Internet (the LED status is blue), you can use your in.touch 2 app any time your device is also connected to the Internet (wireless or cellular network), even if you are away from home.

To have access to your spa away from home, you will need to have previously linked your mobile device to your spa on your home network.

Setup your Wi-Fi on your device



Before using your application, go to the Wi-Fi section of your device's settings. Make sure you are connected to your home network. This needs to be the same Wi-Fi provided by the router to which you connected your Home Transmitter.

Start the in.touch 2 application

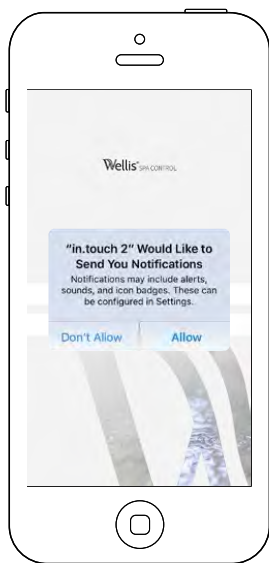

Find the icon for the in.touch 2 application, then tap on it to open it.

The first time you use the application a message will ask you: "in.touch 2" Would like to send you notifications. If you choose Allow, the application will send you notifications about the status of your spa. If you choose Don't Allow, the application will not send you notifications.

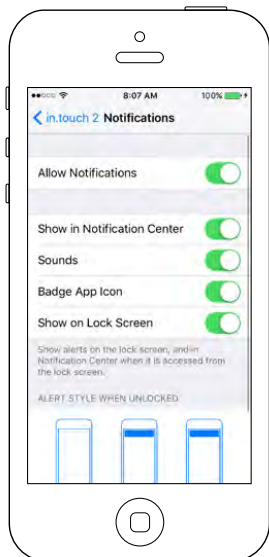

If you change your mind later concerning notifications, you may add or remove notifications for the in.touch 2 application.

On iOS, go in your settings menu and choose in.touch 2. Select the notifications menu, you can turn notifications on or off from this page.

On Android, go to your settings menu and then into the notifications menu. Select the in.touch 2 app, from this page you may turn notifications on or off.

Login page

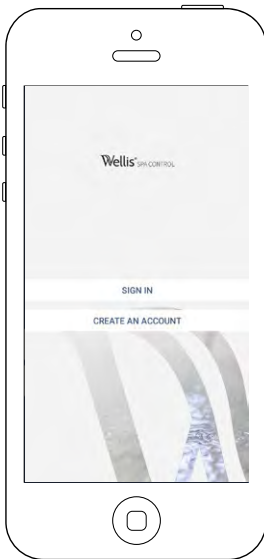

Before using your application, you must create an account first and then, you'll be able to sign in. Your account will give you the opportunity to have access to your spa from any in.touch 2 application.

New account creation

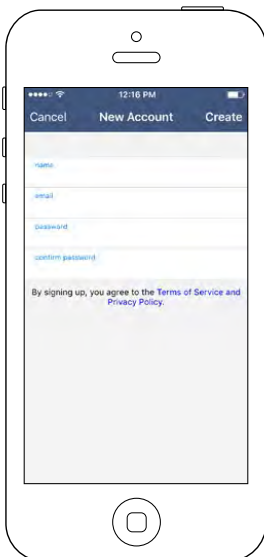

When you choose to create a new account, you agree at the same time our Terms of Service and our Privacy Policy. You can read them at any time through this link: <https://geckointouch.com/legal>

Choose a spa







This page displays all the spas detected by your application.

To detect your spa, you need to connect your mobile device to the same network to which you connected your Home Transmitter.

Once you have done a connection with the spa its name will be saved on this page to allow you to connect to this spa from anywhere.

To add a spa later on, go to p. 26 of this techbook for instructions. The RF signal strength (communication between the two in.touch 2 transmitters) is illustrated on the Select a spa page. There are 5 possible states:

-  • Signal superior to 80%
-  • Signal between 80% and 51%
-  • Signal between 50% and 31%
-  • Signal below 30%
-  • The Spa Transmitter is not available

Home page

The main screen gives you access to your accessories, water temperature, water care and settings.

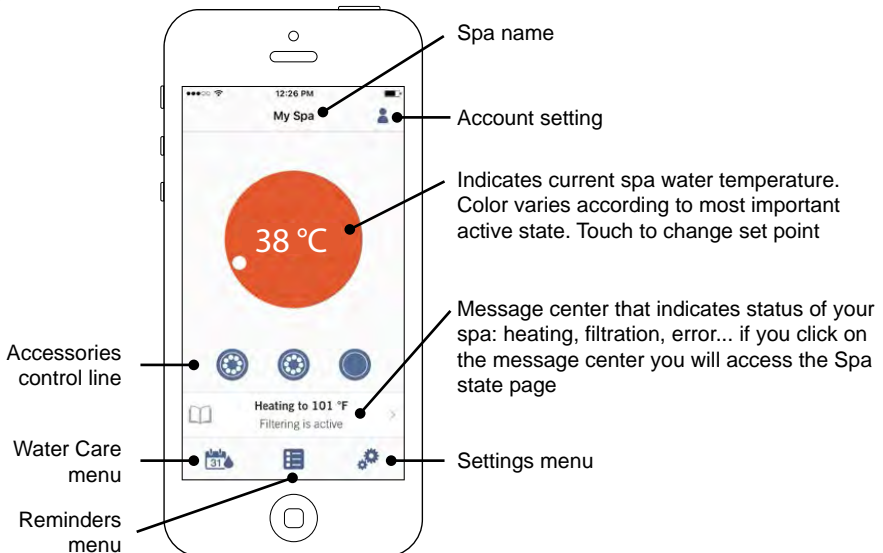

Spa state

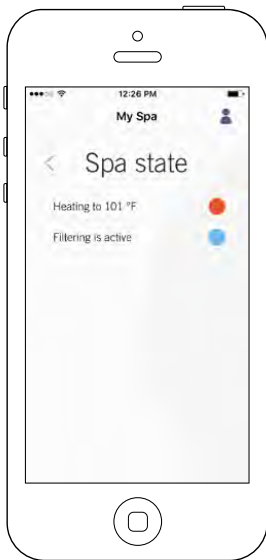

This page displays all the active states of your spa. Below is a quick description of each state you may encounter on your spa. Each state is associated to a priority and color that determines the color of the widget on the home page.

- Indicates that there is an error on your spa.
- Indicates that there is presently an active user demand on your spa (ie. pump, blower or light is on).
- Indicates that your spa is now heating to your set point.
- Indicates that your spa is now in a filtering cycle.
- Indicates that your spa is now in economy mode.
- Indicates that your spa is running normally (there is no user demand, heating, no filtration or economy active).

The widget on the home page displays a single color at a time. The color displayed is decided by priority of state. The established priority is as listed above.

Change temperature

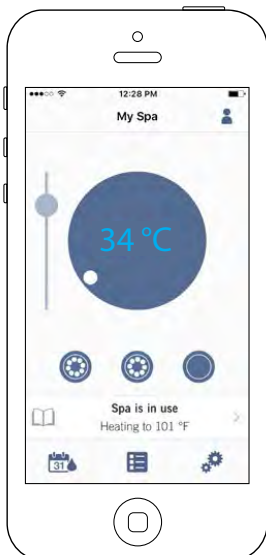

Touch the centered widget to reveal the temperature control bar.

Use the slider on the control bar to change your spa's temperature* set point.

** If you are in economy mode your spa temperature will be 20°F below your set point.*

Turn on/off accessories



According to your spa pack configuration, you can start or stop an accessory by simply touching the associated icon. The icon will become animated when the accessory is on. Simply press on the icon to start or stop the accessory.

If your accessory has more than one speed, press the button until the desired speed is reached.

The icon designs are customized according to your spa pack configuration:



Turn on/off the lights



To control your spa lights, simply press the button to turn it on or off

Control your in.mix 300



This menu is only available if an in.mix 300 is detected in your spa accessories

To turn on or off the in.mix 300, you can use, if you want, the light icon on your home page. To go to your in.mix 300 page, simply swap to the left.

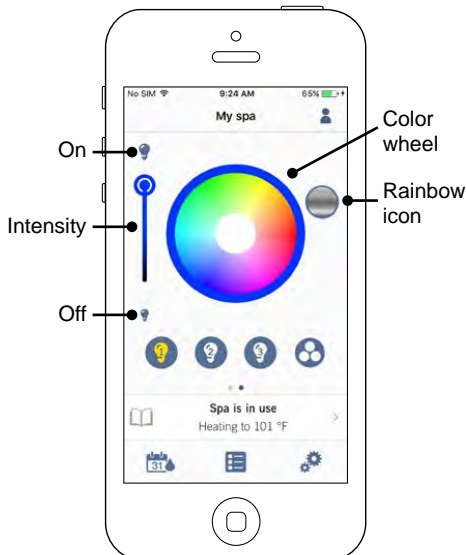

The light bulb icons allow you to turn on and off your in.mix 300.

To change the color, use the color wheel to choose the one you want. On the left side, the intensity slider allows you to modify the brightness of your lights. Use the rainbow icon to get color gradation.

Water Care



The Water Care page will help you set up your ideal filtration and heating settings. Choose between Away from Home, Beginner, Energy Savings, Super Energy and Weekender, depending on your need. Touch the Water Care name you would like to activate, a green check-mark will appear on the icon, indicating you have selected it.

By default, each Water Care mode has pre-configured schedules of economy and filtration. To modify Water Care options, touch the pencil icon at the right end of the desired Water Care to open its menu.

Below you have a short description of each Water Care at default state:



Away From Home:

In this mode the spa will always be in economy; the set point will be reduced by 7 °C (20° F).



Beginner / Standard:

The spa will never be in economy mode and will be filtering according to the pack's low level configuration.



Energy Savings:

The spa will be in economy mode during the peak hours of the day and resume normal mode on the weekend.



Super Energy Savings:

The spa will always be in economy mode during peak hours, every day of the week.



Weekender:

The spa will be in economy mode from Monday to Friday, and will run normally on the weekend.

Reminders

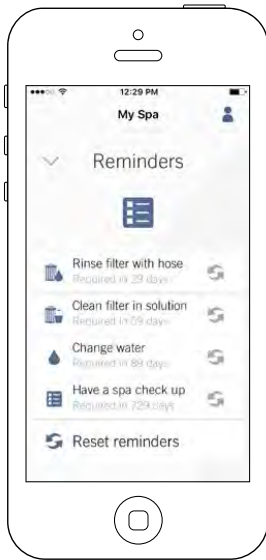

Reminders page will help you to make a follow-up of your maintenance.

The in.touch 2 will remember you to perform required maintenance tasks on your spa, such as rinse filter or clean filter. Each task has its own reminder duration based on normal use. The owner can reset his reminders after the spa maintenance.

Modifying schedules

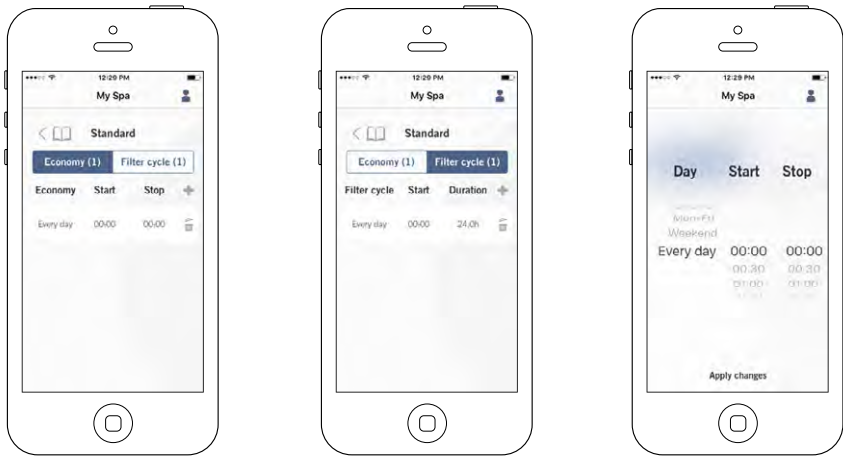

In this menu it is possible to add, remove or edit schedules of economy or filtration.

To have access to this menu, simply touch the tabs:
Water Care menu - the little pen at the right of the wanted water care

Touch the **Economy** tab to modify the economy schedules and **Filter cycle** tab for the filtration schedules. You can add economy or filtration schedules by touching the « + » symbol.

To delete a schedule, touch the garbage can icon at the right end of the desired line.

You can modify the programmed schedules by selecting one and adjusting the schedule.

You have several possibilities for the schedule (Mon-Fri, weekend, every day, or single days). The schedules will be repeated weekly. The time and duration are set in 30 minute increments. Once you have set the schedule, use the arrow at the top of the page to go back. Ensure that you have selected the desired Water Care mode in the main Water Care menu.

When an economy schedule is active, the set point will be reduced by 7 °C (20° F), which means that the heating system will not be engaged unless the temperature falls to 7 °C (20° F) below the spa's set temperature.

The filtration schedule is applied to the main filtration pump, most likely pump 1. If your spa uses a circulation pump configured to run 24 hours, the screen will show purge schedules instead of filtration. The purges are pre-programmed for a fixed number of minutes, therefore the duration will be set to N/A on the screen and only the start time can be modified.

Spa Settings

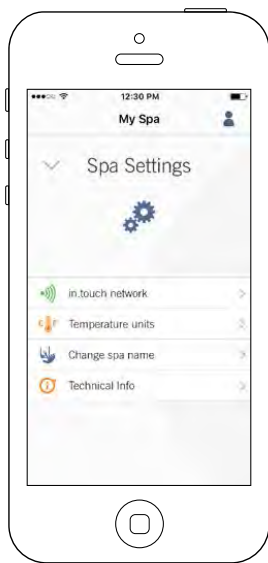

In the Settings page you can access the following:

- *in.touch network*
- *Temperature units*
- *Change spa name*
- *Technical info*

To select an item, tap on the arrow next to it. It will open the selected menu.

in.touch network

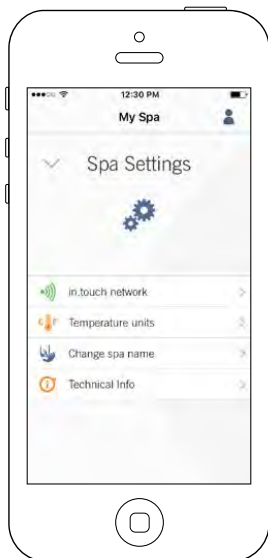

The in.touch network menu allows you to have access to information concerning the RF connection parameters between the Home Transmitter and the Spa Transmitter. This menu gives you access to:

- Channel
- Signal strength
- Reset channel (resets channel to ... default)

To change channels, press on the Channel line.

Change channel



The Change channel page allows you to change the channel used by the two in.touch 2 modules.

In some cases, this can help you to have a stronger signal.

You can have access to this page by touching the following tabs: Spa settings (at the bottom right) - in.touch network - channel

Temperature units



This menu lets you change the units used to display temperature.

You can have access to this page by touching the following tabs: Spa settings (at the bottom right) - temperature units.

Name



This section allows you to edit the name of the spa.

You can have access to this page by touching the following tabs: Spa settings (at the bottom right) - Change spa name

Technical Info



This section shows information about the in.touch 2 software number and the revision numbers of the different components of your system.

You can have access to this page by touching the following tabs: Spa settings (at the bottom right) - Technical info

Settings

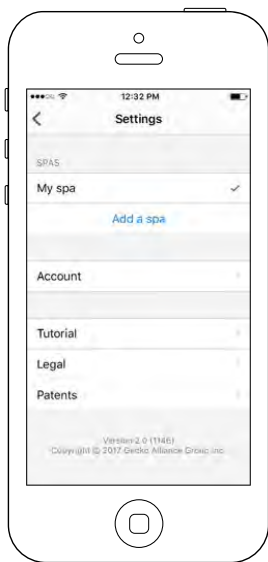

In the Settings page you can access the following:

- *Add a spa from local network*
- *Account*
- *Tutorial*
- **Legal*
- ***Patents*

To select an item, tap on the arrow next to it. It will open the selected menu.

*The button Legal will bring you to this web site :
<https://geckointouch.com/legal>

**The button Patents will bring you to this web site:
<http://geckoportal.com/corpo/#patents>

Add a spa

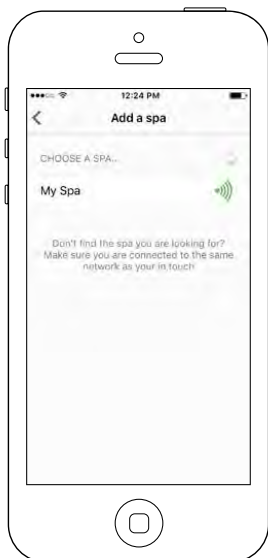

This page displays all the spas detected by your application.





To detect your spa, you need to connect your mobile device to the same network to which you connected your Home Transmitter.

Once you have done a connection with the spa its name will be saved on this page to allow you to connect to this spa from anywhere.

You can have access to this page by touching the following tabs: Settings (up right corner) - Add a spa

The RF signal strength (communication between the two in.touch 2 transmitters) is illustrated on the Select a spa page.

There are 5 possible states:

-  Signal superior to 80%
-  Signal between 80% and 51%
-  Signal between 50% and 31%
-  Signal below 30%
-  The Spa Transmitter is not available

Account

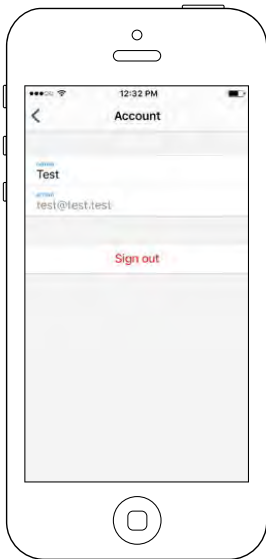

This section gives you access to your account information.

You can have access to this page by touching the following tabs:
Settings (up right corner) - account

Tutorial



This section gives you a quick overview of your in.touch 2 application's functions.

Technical Support invitation

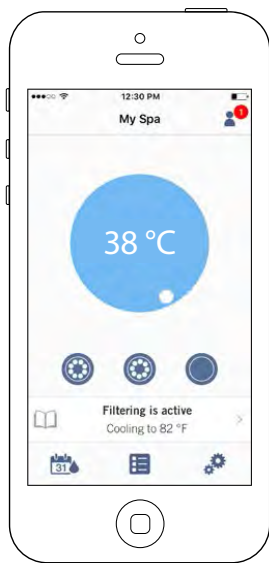

When you receive an invitation for Technical Support, a red circle will be displayed next to the "setting" logo (top right corner).

Authorizing an invitation

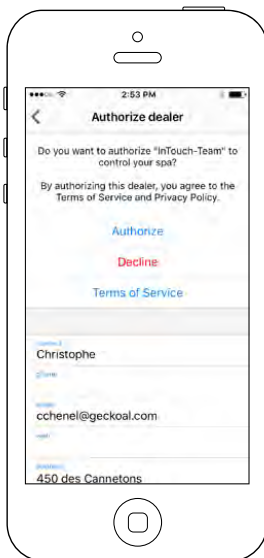
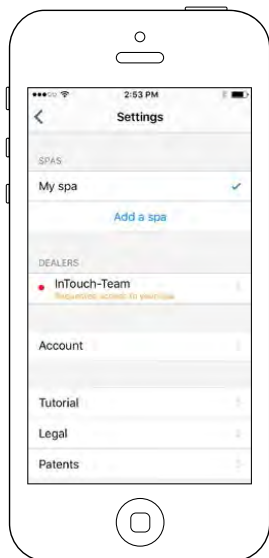

All the invitations you may receive are under the dealers tab in the "settings" menu.

To choose an invitation, simply click on it. You will then see a window authorization to confirm with the dealer's information.

You can also decline the invitation at any time if you want to.

Dealer page



Once you've had a dealer on your in.touch 2 app, you can, at all times, have access to his information.

If you don't want your dealer to have access to your spa anymore, simply swap to the left the "Allow access to your spa" button at bottom of the page.

Both in.touch 2 modules have a status LED to help diagnose problems, if any occur.

Troubleshooting

There are 2 different modules in the in.touch 2 kit: The Home Transmitter (EN Module) and the Spa Transmitter (CO Module). They communicate together via an RF link. The Home Transmitter is responsible for the Ethernet communications and the Spa Transmitter is responsible for the spa communications.

in.grid Heating Management

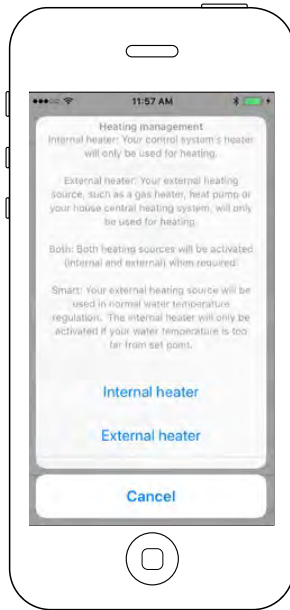
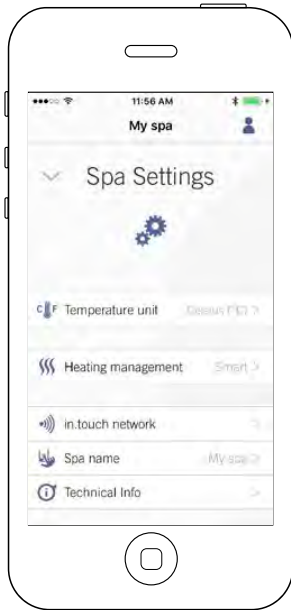

Heating management will appear when an in.grid is detected.

You can change your in.grid heating management without the need to open the spa skirt to change the jumper.

To do so, go to your Spa Settings - Heating management.

You can choose between 4 modes:

- Internal Heater
- External Heater
- Both
- Smart

Both in.touch 2 modules have a status LED to help diagnose problems, if any occur.

Troubleshooting

There are 2 different modules in the in.touch 2 kit: The Home Transmitter (EN Module) and the Spa Transmitter (CO Module). They communicate together via an RF link. The Home Transmitter is responsible for the Ethernet communications and the Spa Transmitter is responsible for the spa communications.

2- INT (INTERNAL)

This mode provides an easy way to revert back to standard water regulation using the internal heater in case of problem with the external heating system.

3-EXT (EXTERNAL)

Use this mode for a maximum energy saving purpose. The spa control system will only use your external heating system to regulate the water temperature. In normal operation, the internal heater will never be activated.

Freeze Protection

Freeze protection has been added because EXT (EXTERNAL) mode does not allow the activation of the internal heater. In cold weather, if it becomes impossible to keep the water over freezing point, the help of the internal heater will then be needed. This is the only time the freeze protection will come in.

At any time, if the water temperature drops to 40°F (4.5°C), the resistive heater will give a boost to avoid freezing. The freeze protection will stay active until water temperature reaches the minimum allowed set point (usually 15°C/ 59°F). Normal EXT mode will resume functioning thereafter.

4- BOTH (BOTH SYSTEMS ALL AT ONCE)

The spa control system will always use the external heating system AND the internal heater simultaneously to regulate the water temperature; they are both activated or deactivated at the same time.

5- SMART (ENERGY SAVINGS)

The spa control system will always use the external heating system to regulate the water temperature. If the temperature falls too far below your set point (-19°C/-2.5°F), the internal heater will be activated to help your external heating system reach the set point.

WIRING DIAGRAM - W3000

W3000



WIRING DIAGRAM - W3000

CONNECTIONS

CONNECTING HIGH VOLTAGE ACCESSORIES: ALL MODELS

Two options are available with Y Series spa packs for connecting high voltage accessories: 0.250" quick-connect terminals, or AMP connectors conform to industry standards.

CONNECTING HIGH VOLTAGE ACCESSORIES: EUROPEAN MODEL IN.YE

For the connection to the 0.250 inch terminals, the high voltage accessories must be provided with female quick connect terminals, straight and non-insulated for all types of connections, including the ground. Only 230 V accessories may be connected to the corresponding terminals of the printed circuit of the in.ye. Refer to the following tables for correct connections. Note that all female terminals must be correctly and completely seated on the printed circuit terminals for proper current ratings.

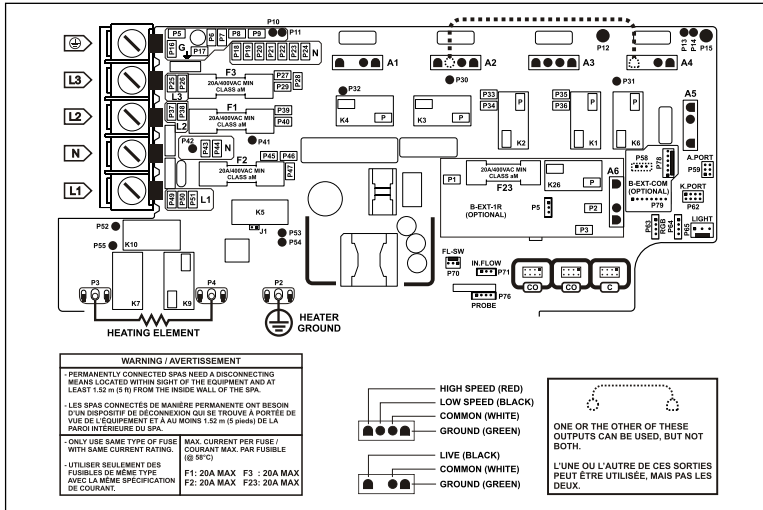

CONNECTION FOR MODEL WITHOUT AMP CONNECTORS:

DIRECT OUTPUT 1 (A5)		PUMP 1 (A3)		PUMP 1 (A2) (in.ye-5 CE)		PUMP 3 (A4) (in.ye-5-CE only)	
Voltage	230 V	Voltage	230 V	Voltage	230 V	Voltage	240 V
Green / ground	P16	Green / ground	P8	Green / ground	P7	Green / ground	P9
Black / line	P45	Black / low speed	K2-P	Black / low speed	K6-P	Black / line	K6-P
White / common	P22	Red / high speed	K1-P	Red / high speed	K3-P	White / common	P21
		White / common	P20	White / common	P19		
Pump 2 (A2) (in.ye-3-CE)		Circulation pump* (A1)		Light (12 V dc, 1.3 A Max.)**		Optional output (A26) (in.ye-4-CE or -6-CE only)	
Voltage	230 V	Voltage	240 V			Voltage	230 V
Green / ground	P7	Green / ground	P6	P65		Green / ground	P17
Black / low speed	K2-P	Black / line	K4-P	LEDs RGB (in.lu.me only)		Black / line	K26-P
White / common	P19	White / common	P18	P63; P64		White / common	P44

* Ozonator and circulation pump can be combined on the same output via the optional splitter PP1.

** Max. available current for Light and LEDs RGB together.

This table shows typical connections. OEMs may have a different connection scheme.

WIRING DIAGRAM - W3000

CONNECTIONS

HEAT.WAV WATER HEATER CONNECTIONS

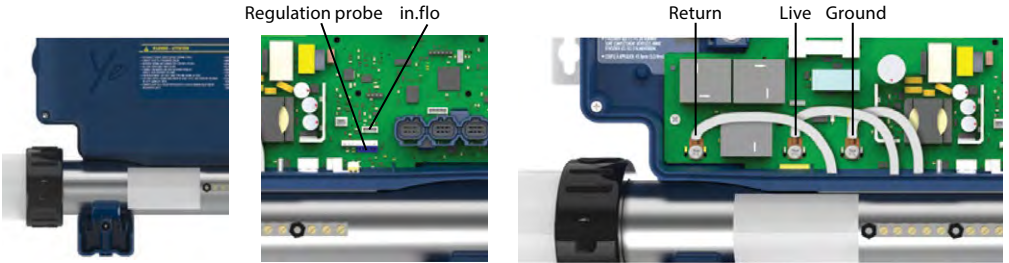

in.ye systems come with a high performance heat.wav heater. With no pressure switch, it features in.flo integrated dry-fire protection.

The heat.wav heater is factory configured for 240 V / 4 kW, but it can be converted to a dedicated 120 V / 1 kW by simply adding a cable connection. (120 V conversion is available on North American in.ye-3 models only).

The heat.wav heater is also offered in 240 V / 5,5 kW or 240 V / 2 kW versions.

heat.wav specification summary:

- Supports 120 V or 240 V
- Incoloy® heater element
- Protected by external breaker (not fused)*

**Note : European models are 230-240 V only and are fuse protected.*

Part numbers:

9917-101959 (cable for conversion)

9920-101449 (5.5 kW heat.wav heater)

WIRING DIAGRAM - W3000

ELECTRICAL WIRING

ELECTRICAL WIRING: EUROPEAN MODEL IN.YE

Refer to wiring diagram in the enclosure box lid for more information.

⚠ WARNING!
in.ye.ce models must always be connected to a circuit protected by a Residual-Current Device (RCD) having a rated operating residual-current not exceeding 30 mA.
Correct wiring of the electrical service box, RCD, and pack terminal block is essential!
Check your electrical code for local regulations. Only copper wire should be used, never aluminum.

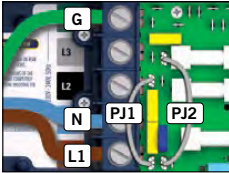

1-phase

Connect PJ1 between P37 and P49.
Connect PJ2 between P50 and P26.

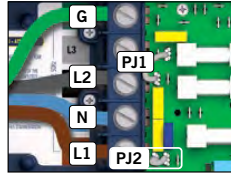

2-phase

Connect PJ1 between P37 and P26.
Connect PJ2 between P50 and P49.

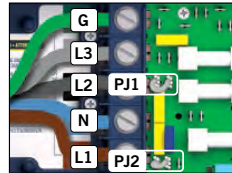

3-phase with single neutral

Connect PJ1 between P7 and P10.
Connect PJ2 between P13 and P74.

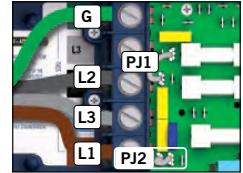

3-phase Delta (no neutral)

Connect PJ1 between P37 and P38.
Connect PJ2 between P50 and P49.

input voltage: 230V, 50Hz (Line-to-Neutral)

Only for countries where Line-to-Line input voltage: 230V, 50Hz.

Insert each wire into the appropriate socket of the main entry terminal block according to the color code indicated on the sticker. Use a flat-head screwdriver to tighten the screws on the terminal (please refer to the sticker inside the casing to see the torque to apply).

After making sure wires are securely connected, push them back into the box and replace the cover. Do not over tighten cover screws (torque to 8 in. lb max {0.9 N.m}).

Connect the bonding conductor to the bonding lug on the front of the spa pack (a grounded electrode conductor should be used to connect the equipment grounding conductors). Bonding conductor must meet local electrical code.

WIRING DIAGRAM - W3000

ELECTRICAL WIRING

ELECTRICAL WIRING : ALL MODELS



Warning

Disconnect power before starting electrical work. Wiring must be completed by a qualified electrician and must be done in accordance with the local electrical code.

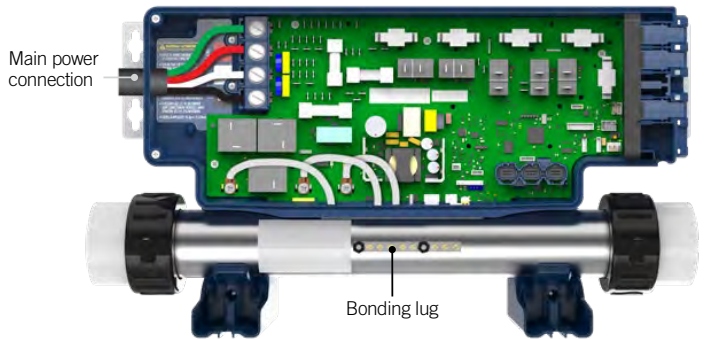

To complete the electrical connections of our in.ye control system you will need a Phillips screwdriver and a flat-head screwdriver (slotted head size between 5/16" and 3/8").

Remove the screws from the system control lid and remove it.

Remove 5 1/2" (142 mm) of cable insulation.

Strip away 1" (25 mm) of insulation from each wire.

Pull the cable through the cutout of the box and secure it with a NPT strain relief* (hole diameter 1,335" [34,42 mm]). Ensure that the NPT strain relief clamps are around the outer sheath of the cable.

* For CE use an IEC certified plastic bushing that will maintain the IPX5 rating.

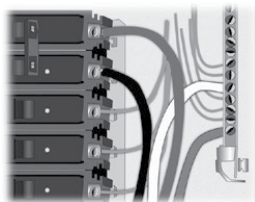
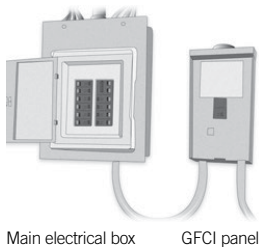

Warning

For units to be installed in other than single-family dwellings, a clearly labeled emergency switch shall be provided as part of the installation. The switch shall be readily accessible to the occupants and shall be installed at least 5' (1.52 m) away, adjacent to, and within sight of the unit.

This product must always be connected to a circuit protected by a ground fault interrupter.

Proper wiring of the electrical service box, GFCI and in.ye terminal block is essential!

Check your electrical code for local regulations. Only copper wire should be used, never aluminum.



Disposal of the product

The appliance (or the product) must be disposed of separately in accordance with the local waste disposal legislation in force.

BREAKER SETTING



Config

Please do not make changes in the electrical configuration section unless you are a qualified electrician.

In this section you can change the low-level configuration, number of phases, input current and heat pump current.

Use Up/Down to move between parameters, and the Light key to select a parameter to change. Please refer to the techBook of your specific control system for spa for details about the low level settings.

Once you have changed the Number of Phases in the menu, you will be unable to use the Up/Down keys to return to the Low-level Configuration menu. Please go back and re-enter the Config menu.

Note with version 15.00 and higher:

Depending on the pack configuration, a code may be required to change these settings. This code is "5555".

BREAKER SETTING

POWER UP AND BREAKER SETTING

IMPORTANT Please read the following before starting the device.

Verify that all accessories are linked to the ground lug and connected to the to the control system.

A minimum flow of 68 LPM (18 GPM) is required. Make sure that all valves are open in the spa plumbing and that the water flow is sufficient between the main pump and the water heater.

Turn on the breaker.

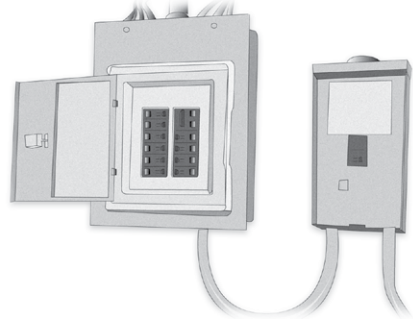

IN.FLO DRY-FIRE PROTECTION

At start up, the in.flo's detector verifies the water flow according to the following sequence:

The Pump 1 or the circulation pump runs for a period of 2 to 5 minutes.

The display will show "--" during the flow verification. After this time, the system confirms if flow is adequate or not.

If the flow is sufficient, the temperature of the water is displayed on the keypad screen. When the water has reached the consigned temperature plus 0.45°C (0.8°F), the water heater turns off.

COMMON HARDWARE ISSUES

Problem	Usual Cause	Solution
System not operating	<ul style="list-style-type: none"> – House circuit breaker tripped or in OFF position 	<ul style="list-style-type: none"> – Reset circuit breaker on house breaker panel
Heater not operating	<ul style="list-style-type: none"> – Water level too low – Heater mode not selected – No power to heater – Heater not operating – Jets are closed 	<ul style="list-style-type: none"> – Add water to reach 6" (15.5 cm) below top lip of spa – Open all jets – Refer to temperature/heater functioning – Check house circuit breaker – Contact dealer
Water not clean	<ul style="list-style-type: none"> – Clogged or blocked floor suction or skimmer – Filter clogged (dirty) – Poor water chemistry – Insufficient filtering time – Improper maintenance – High content of solids in water 	<ul style="list-style-type: none"> – Clean floor suction/skimmer – Remove blockage – Clean or replace – See Maintenance section – Run filtration mode longer – Contact dealer – Use clarifier or drain and refill spa
Abnormal water usage	<ul style="list-style-type: none"> – Excessive evaporation and/or splashing 	<ul style="list-style-type: none"> – Use spa cover and refill as necessary
Overheating	<ul style="list-style-type: none"> – High ambient temperature 	<ul style="list-style-type: none"> – Contact dealer
Low water flow from jets	<ul style="list-style-type: none"> – Operating in FILTER mode-low speed – Clogged or blocked suction or skimmer – Dirty filter – Jets in OFF position – Slice valves closed 	<ul style="list-style-type: none"> – Select hi-speed jets – Clean floor suction/skimmer – Remove blockage – Clean or replace – Open jets – Contact dealer
Noisy pump and motor	<ul style="list-style-type: none"> – Clogged floor suction or skimmer – Low water level – Damaged or worn motor bearings 	<ul style="list-style-type: none"> – Clean floor suction/skimmer – Add water to normal water level (6" or 15.5 cm below lip) – Contact dealer
No water flow from jets	<ul style="list-style-type: none"> – Pump not primed – Adjustable jets turned off – House circuit breaker tripped, no power to system – Faulty pump or motor – Pump surges – Slice valves closed 	<ul style="list-style-type: none"> – See Priming section – Turn on jets – Reset circuit breaker at house panel – Low water. Check level on Weir door – Contact dealer
Water leakage from under spa	<ul style="list-style-type: none"> – Check unions & drain hoses 	<ul style="list-style-type: none"> – Close or tighten as necessary
No air flow from jets	<ul style="list-style-type: none"> – Air control not open – Jet nozzle not seated properly – Jet nozzle missing 	<ul style="list-style-type: none"> – Open control – Check jet nozzles – Inspect jets and replace as needed
Motor will not operate	<ul style="list-style-type: none"> – House circuit breaker tripped or in OFF position – Improper or defective wiring or electrical supply – Thermal Overload Protection switch tripped 	<ul style="list-style-type: none"> – Reset circuit breaker – Contact dealer – Auto reset after motor has cooled. Contact dealer if motor continues to cycle
The spa will not shut off	<ul style="list-style-type: none"> – Spa trying to heat – Spa is in filter cycle 	<ul style="list-style-type: none"> – Check Set Temperature – Check Filter Times

